

Matemáticas

Cuaderno Ejercicios

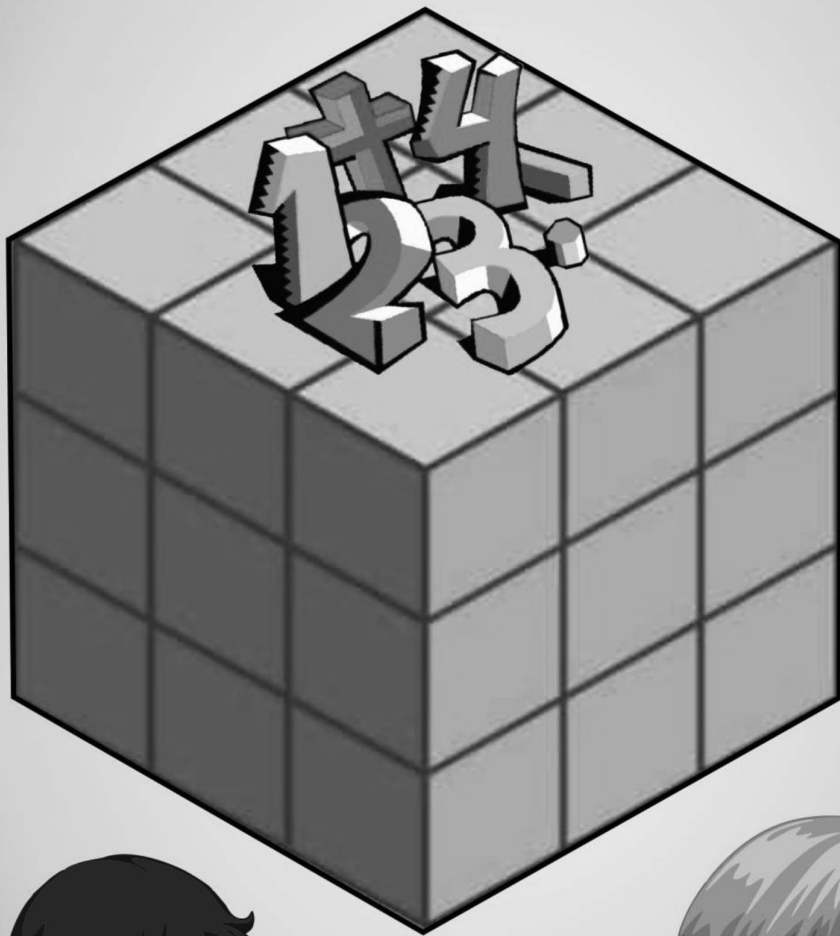

1º



Unidad 1



¡Qué divertida la matemática!

Lección 1

Reconozcamos relaciones

1 Marca con una "x" los objetos más grandes y colorea los más pequeños.

a)

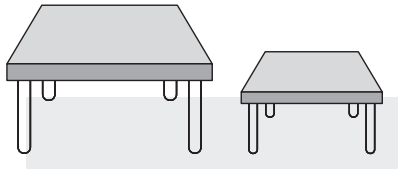

b)



2 Marca con una "x".

a) El conejo más pequeño.

b) El vaso más grande.

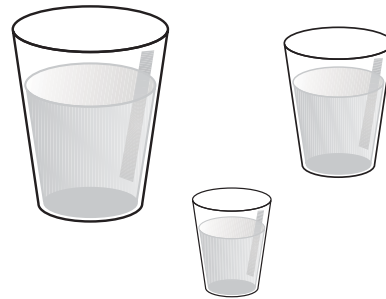
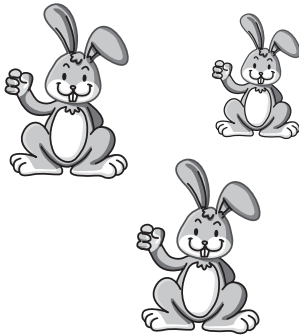

3 Marca con una "x".

a) El carro tan grande como el que está encerrado.



b) La camiseta tan pequeña como la que está encerrada.

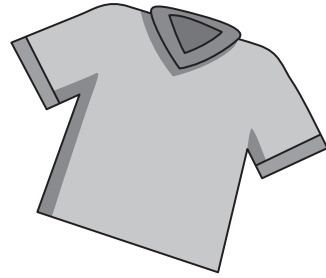

4 Encierra.

a) El lápiz más delgado.

b) El niño más gordo.

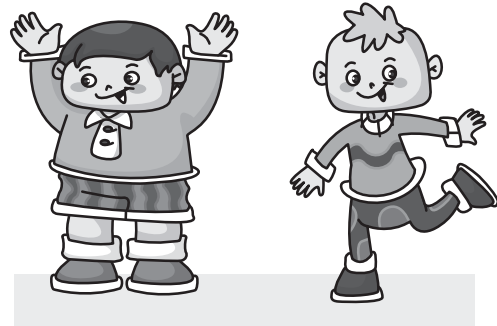
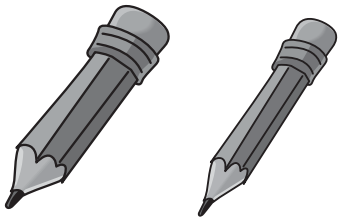

5 Colorea el objeto con el color indicado.

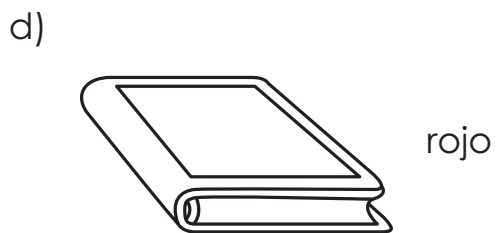
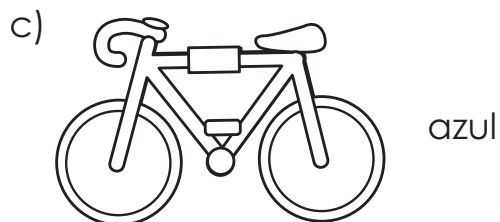

Lección 2

Reconozcamos posiciones y el tiempo

6 Marca con una 'x'.

a) El objeto más cerca de la niña.

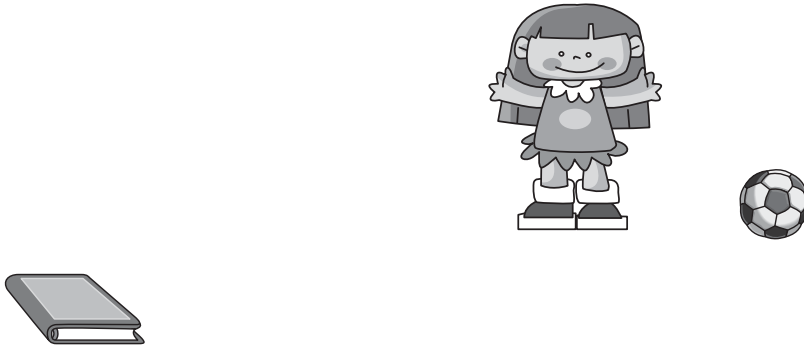

b) El objeto más lejos de la ventana.

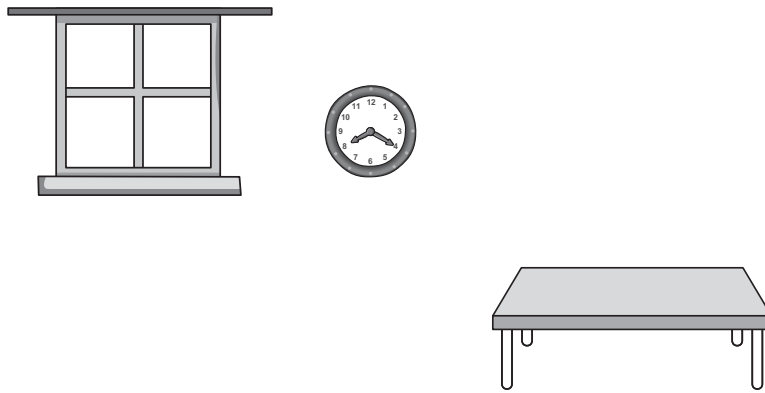

7 Encierra.

a) La fruta que está a la izquierda de los mangos.

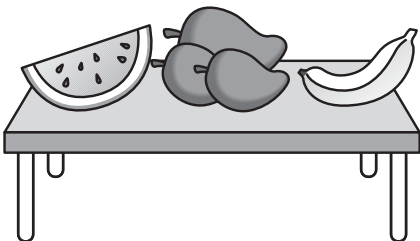

b) El objeto que está a la derecha del reloj.

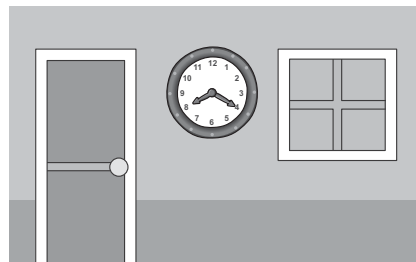

8) Dibuja una pelota a la derecha de la niña y una fruta a la izquierda de la niña.

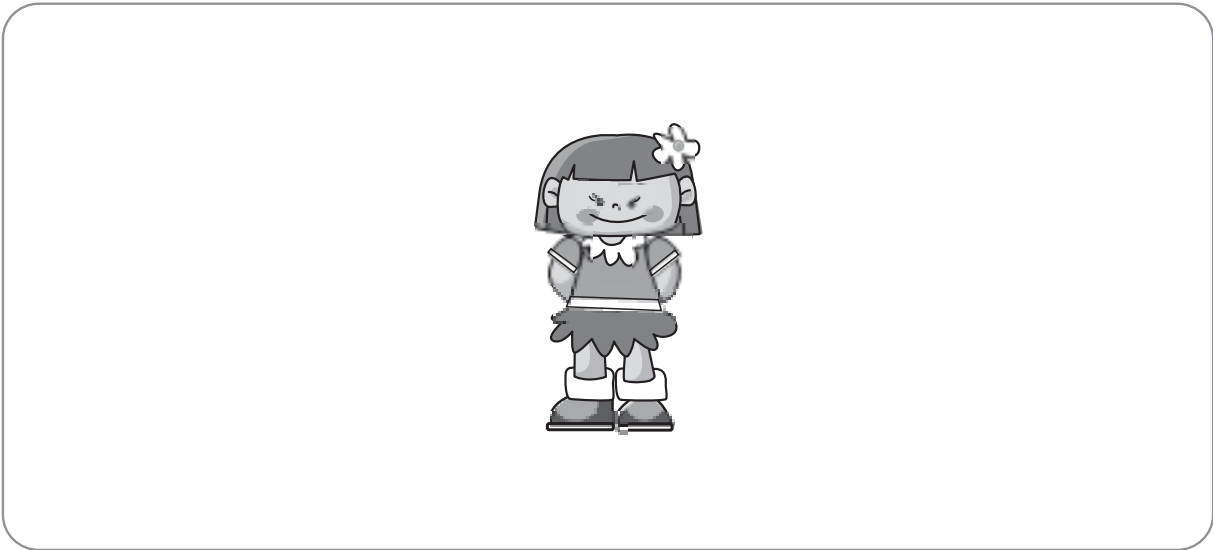

9) Sigue las indicaciones.

a) Ordena las actividades que realizas durante el día.

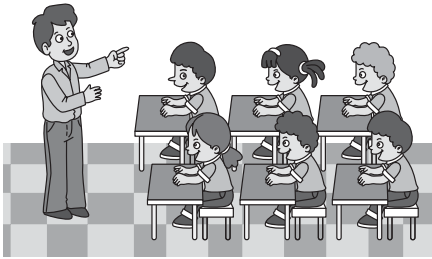

b) Encierra una semana.

Abril						
domingo	lunes	martes	miércoles	jueves	viernes	sábado
						1
2	3	4	5	6	7	8
9	10	11	12	13	14	15
16	17	18	19	20	21	22
23	24	25	26	27	28	29
30						

c) Colorea los nombres de los días de la semana que vas a la escuela.

d) ¿Cuándo es tu cumpleaños? _____

e) ¿Cuántos años tienes? _____

10 Encierra.

a) El animal que nació después. b) La fruta como estaba antes.

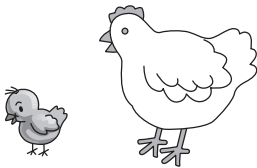

c) El huevo como estaba antes. d) El pan después de morderlo.



11 Colorea de verde el día de hoy, azul el día de ayer y amarillo el día de mañana.

domingo	lunes	martes	miércoles	jueves	viernes	sábado
---------	-------	--------	-----------	--------	---------	--------

Lección 3

Formemos colecciones

12 Marca con una "x".

a) El de diferente color.



b) El de diferente tamaño.



c) El de diferente forma.

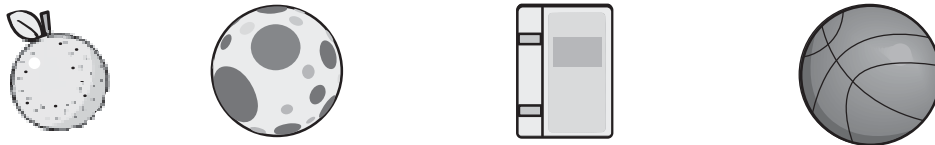

13 Une con una línea el objeto de la derecha y el grupo de la izquierda por su característica.

			•	•	
			•	•	
			•	•	
			•	•	



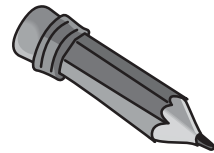
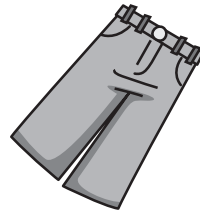
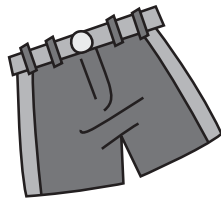
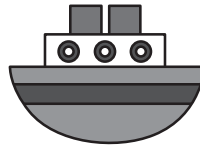
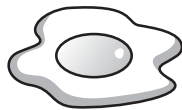
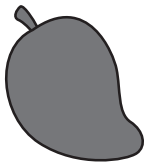
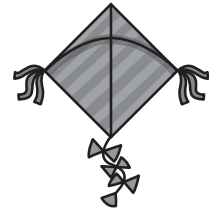
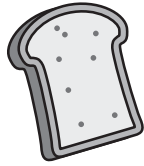











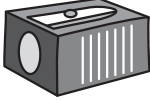

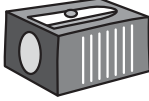

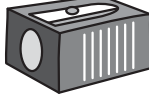

14 Encierra los objetos según se utilicen: rojo para comer, azul para jugar, verde para vestirse y negro para escribir.

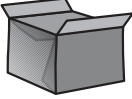
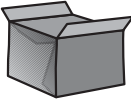

Lección 4

Descubramos series

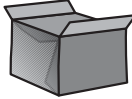
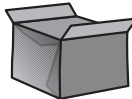
15 a) Encierra el patrón en cada serie.

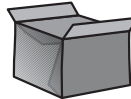
b) Dibuja al lado derecho el patrón de la serie.

						
---	---	---	---	---	---	--

16 Colorea, ¿a cuál animal le tocaría entrar en el gallinero?

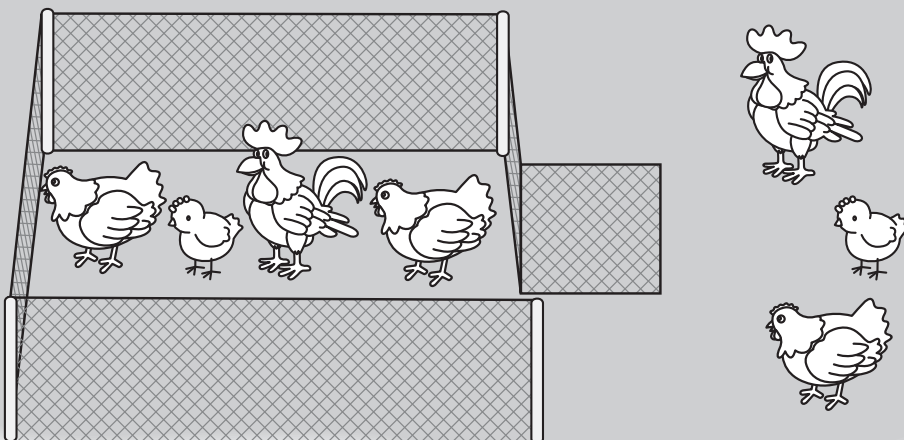

Lección 5

Relacionemos objetos

17 Une con una línea los objetos que se relacionan entre sí.

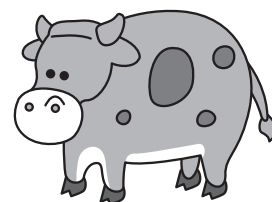
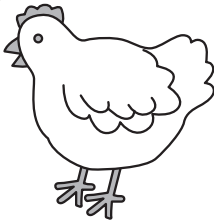
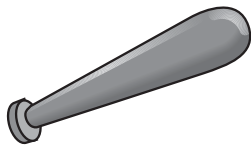
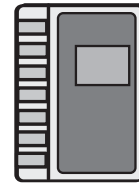
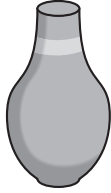

Lección 6

Comparemos grupos

- 18 Usa las tarjetas y compara.
Utiliza "más", "menos" o "igual" y completa las frases.

a)



Hay _____ fresas
que sorbetes.

b)

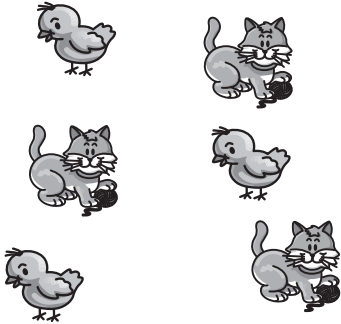

Hay _____ gatos
que pollos.

c)

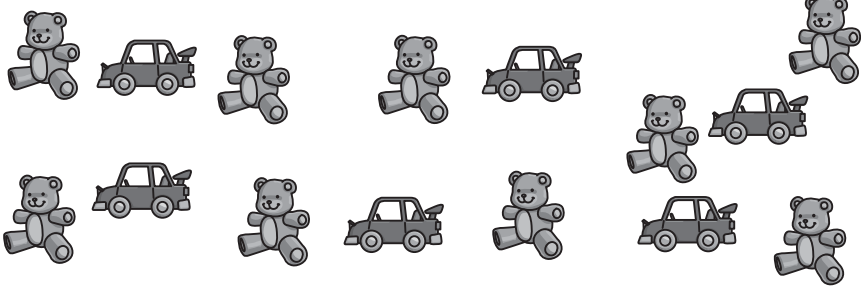

Hay _____ osos que carros.

- 19 Marca con una "x" el nido con muchos huevos. Encierra el nido con pocos huevos. Colorea el nido con ningún huevo.

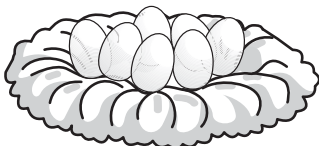

Unidad 2



Contemos y ordenemos

Lección 1

Contemos hasta 5

1 Pinta las marcas y traza los números. Sigue el ejemplo.

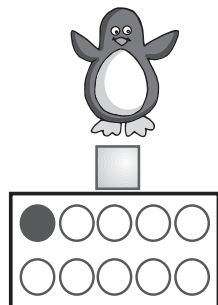

1

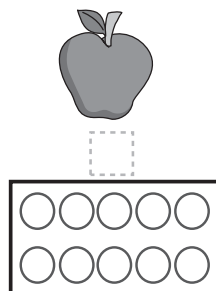

1

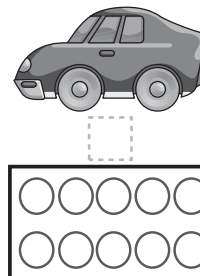

—

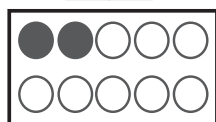
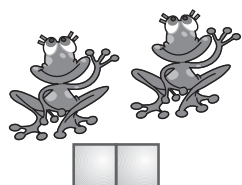

2

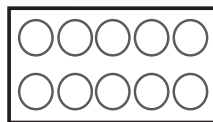
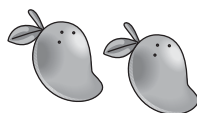

2

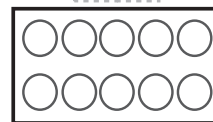

—

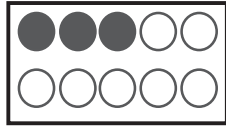
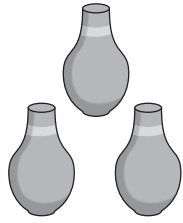

3

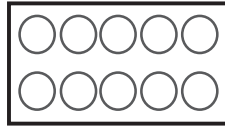
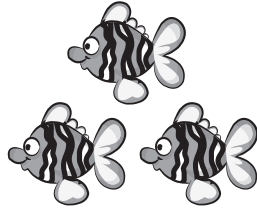

3

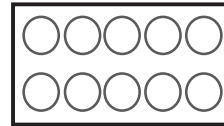
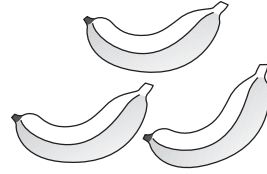

—

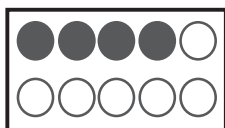

4

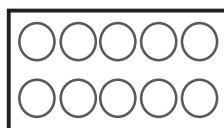
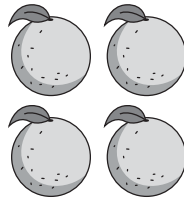

4

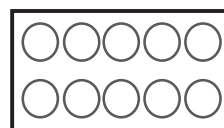
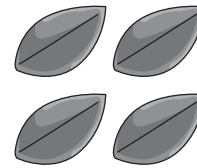

—

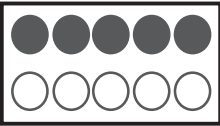
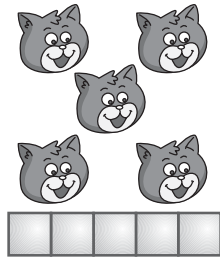

5

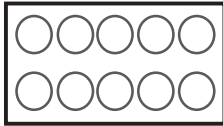
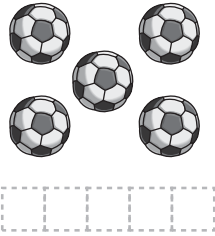

5

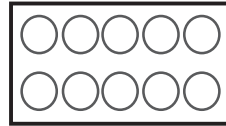

2 Encierra.

a) El número de cada grupo.

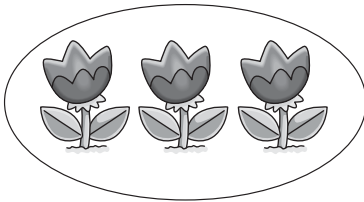

2 3 4

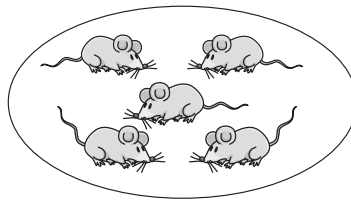

3 4 5

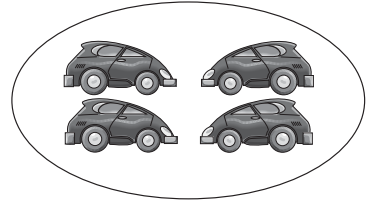

3 4 5

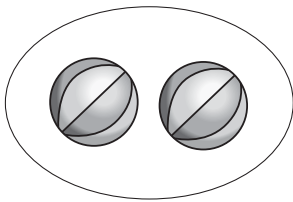

1 2 3

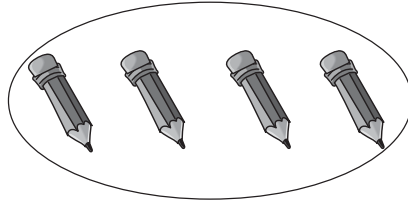

3 4 5

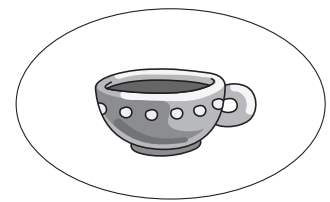

1 2 3

b) El número de cada figura.

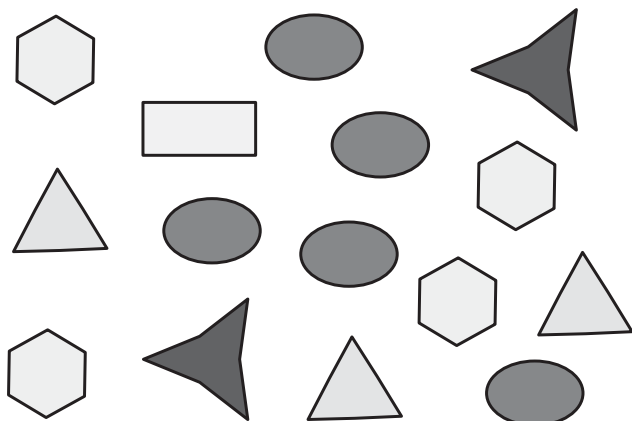









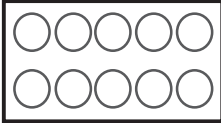

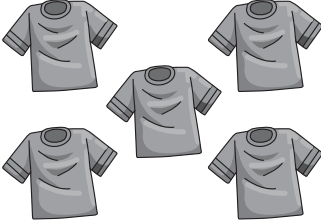
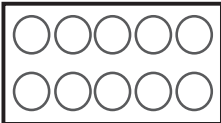
	1	2	3	4	5
	1	2	3	4	5
	1	2	3	4	5
	1	2	3	4	5
	1	2	3	4	5

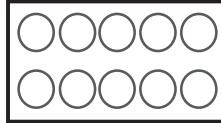

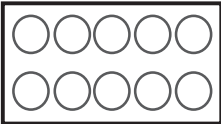
c) La cantidad de figuras.

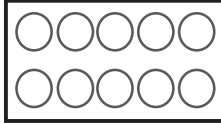
3					
5					
2					
4					
1					







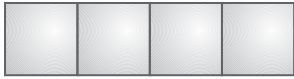

3 Cuenta las figuras, pinta las marcas y escribe el número.

4 Dibuja figuras. Forma grupos del 1 al 5.
Escribe cada número en el cuadrado, como el ejemplo.

   	 
--	--

5 Une con una línea las figuras, los azulejos y los números. Sigue el ejemplo.

	■	■		■	■	4
	■	■		■	■	5
	■	■		■	■	2
	■	■		■	■	1
	■	■		■	■	3

6 Escribe los números del 1 al 5.

1	2	3	4	5

Lección 2

Contemos hasta 9

7 Pinta las marcas y traza los números.

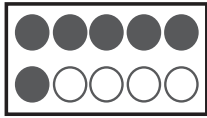
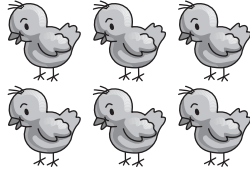

6

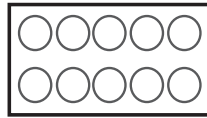
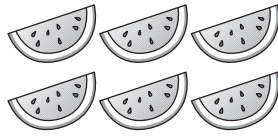

6

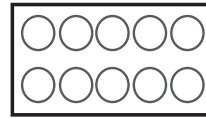

—

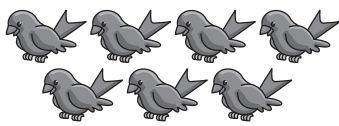

7

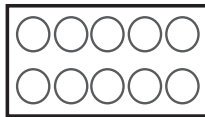
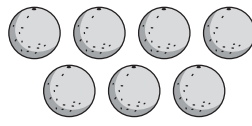

7

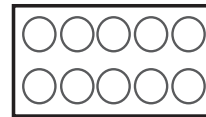
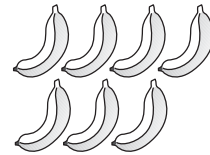

—

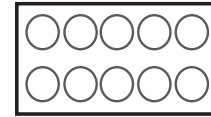
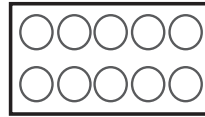
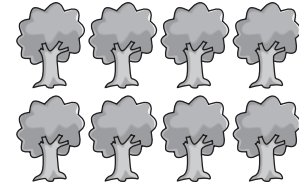
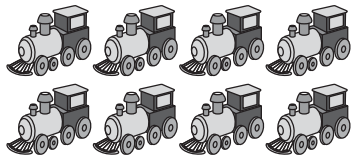

8

8

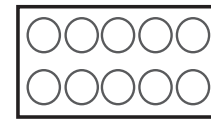
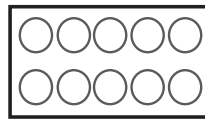
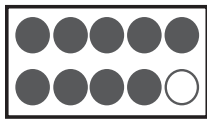
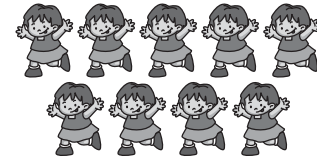
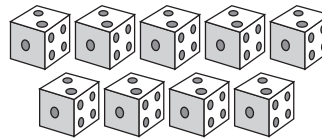
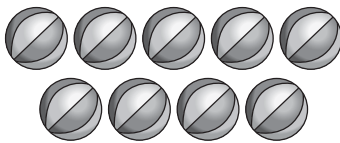

9

9

8) Marca con una "x" el número de objetos en cada grupo.

a)

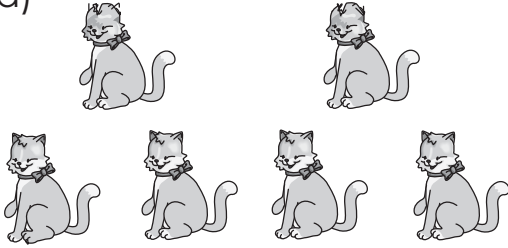

6 7 8 9

b)

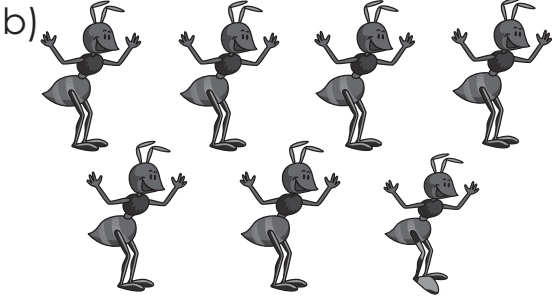

6 7 8 9

c)

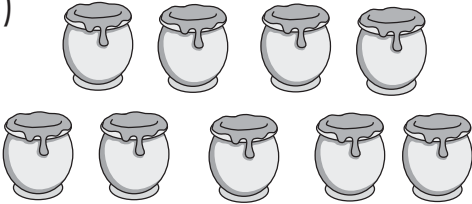

6 7 8 9

d)

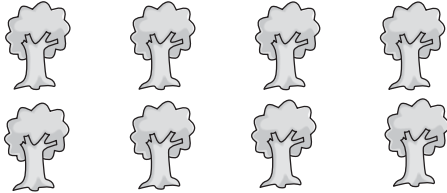

6 7 8 9

9) Cuenta las figuras y escribe el número.

a)

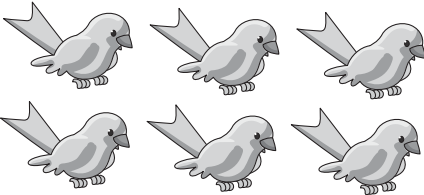

b)

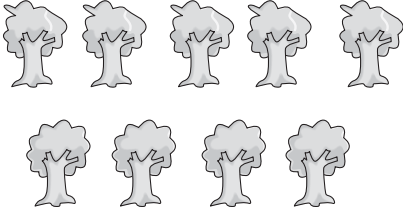

c)



d)

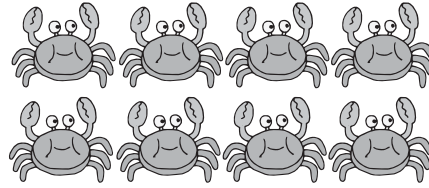

Lección 4

Ordenemos números

10 Encierra el número mayor.

a) 5 y 2

b) 1 y 3

c) 5 y 7

d) 6 y 5

e) 4 y 8

f) 9 y 7

11 Encierra el número menor.

a) 1 y 5

b) 3 y 6

c) 7 y 4

d) 5 y 2

e) 8 y 3

f) 9 y 8

12 Coloca los números 4, 6, 2, 9, 3.

a) De menor a mayor.

b) De mayor a menor.

Lección 5

Formemos números

13) Escribe el número que falta.

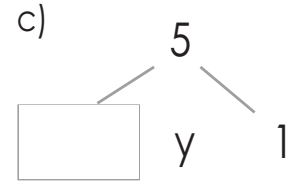
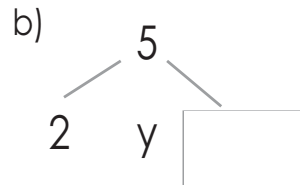
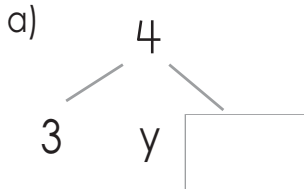

14) Escribe el número que falta.

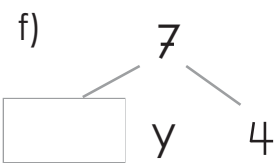
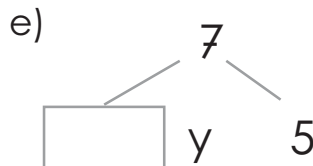
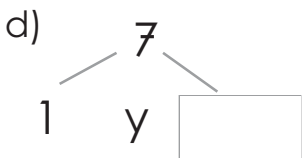
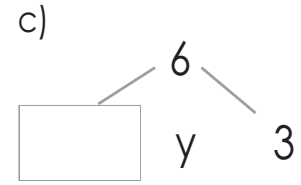
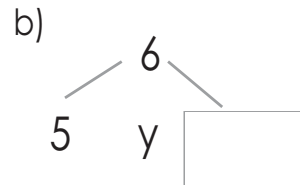
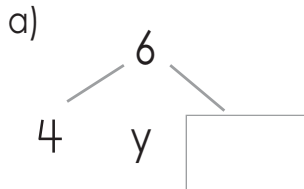

15) Escribe el número que falta.

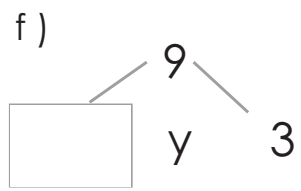
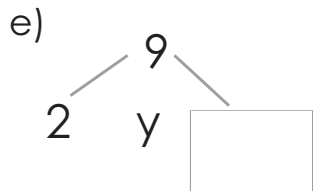
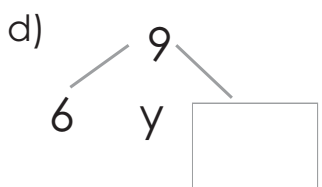
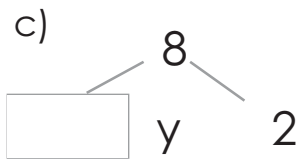
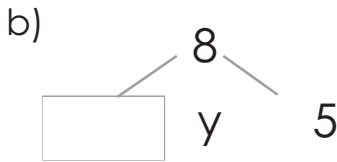
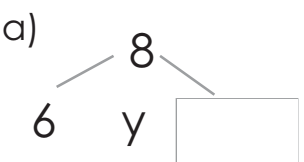

Lección 6

Conozcamos los números ordinales

- 16 Continúa escribiendo los números ordinales hasta el noveno.

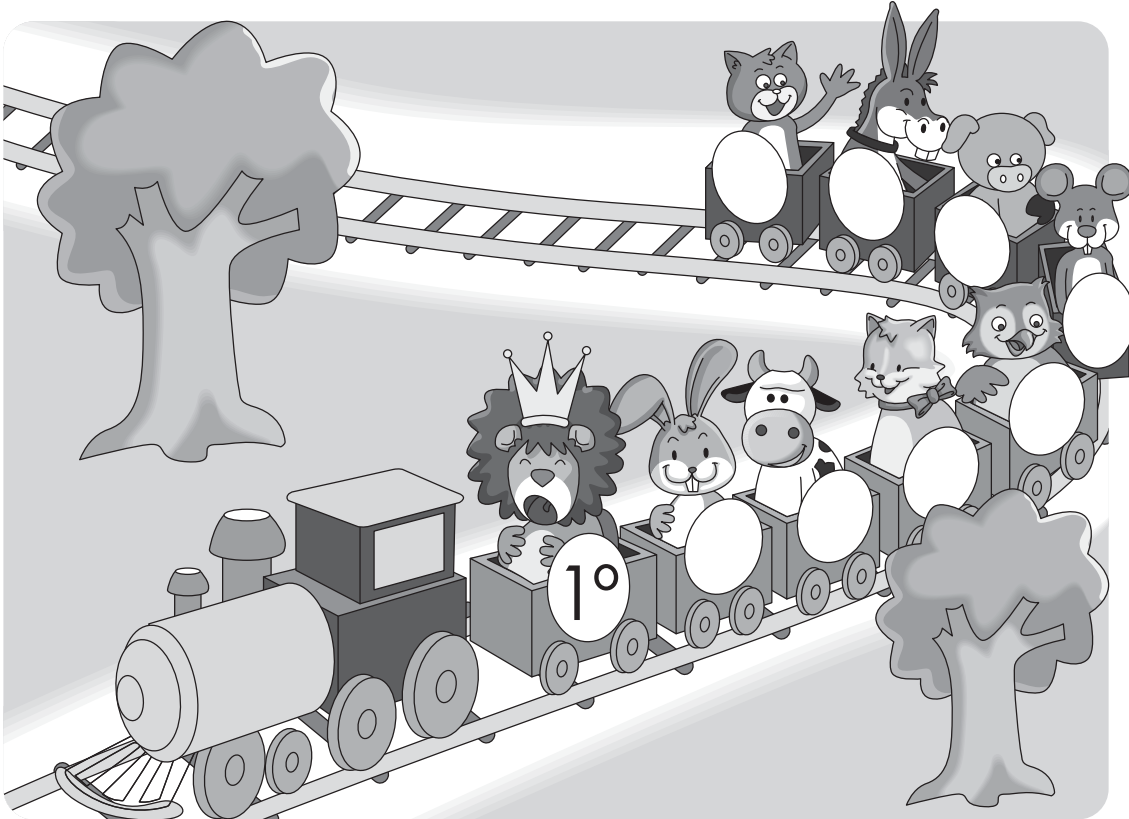

- 17 Encierra.

a) La fruta que está en segundo lugar de izquierda a derecha.

izquierda

derecha

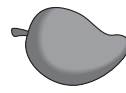

b) El animal que está en cuarto lugar de izquierda a derecha.

izquierda

derecha



c) La prenda de vestir que está en primer lugar de derecha a izquierda.

izquierda

derecha

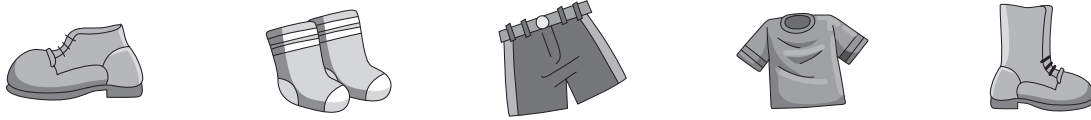

d) El objeto que está en cuarto lugar de derecha a izquierda.

izquierda

derecha



18 Contesta.



a) Escribe el número ordinal de la posición de izquierda a derecha que ocupa la gallina.

b) Escribe el número ordinal de la posición de derecha a izquierda que ocupa la vaca.

c) ¿Qué animal ocupa el cuarto lugar de izquierda a derecha?

d) ¿Qué animal ocupa el séptimo lugar de derecha a izquierda?

e) Encierra cinco animales contando de izquierda a derecha.

f) Marca con una "x" el quinto animal de izquierda a derecha.

Unidad 3



Juguemos con líneas

Lección 1

Reconozcamos líneas por su forma

1) ¿Cuáles son las líneas abiertas y cerradas?
Encierra las abiertas y marca "x" las cerradas.

a)



b)



c)



d)

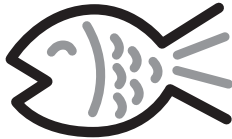

e)



f)



g)



h)



i)

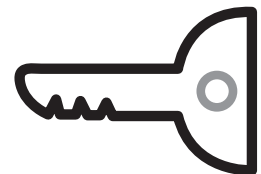

2) Une los trazos de las líneas y su nombre.



•

•

rectas

•

•



•

•

quebradas

•

•



•

•

mixtas

•

•



•

•

curvas

•

•



Lección 2

Reconozcamos líneas por su posición

- ③ Repinta con azul las líneas horizontales, con verde las verticales y con rojo las inclinadas.

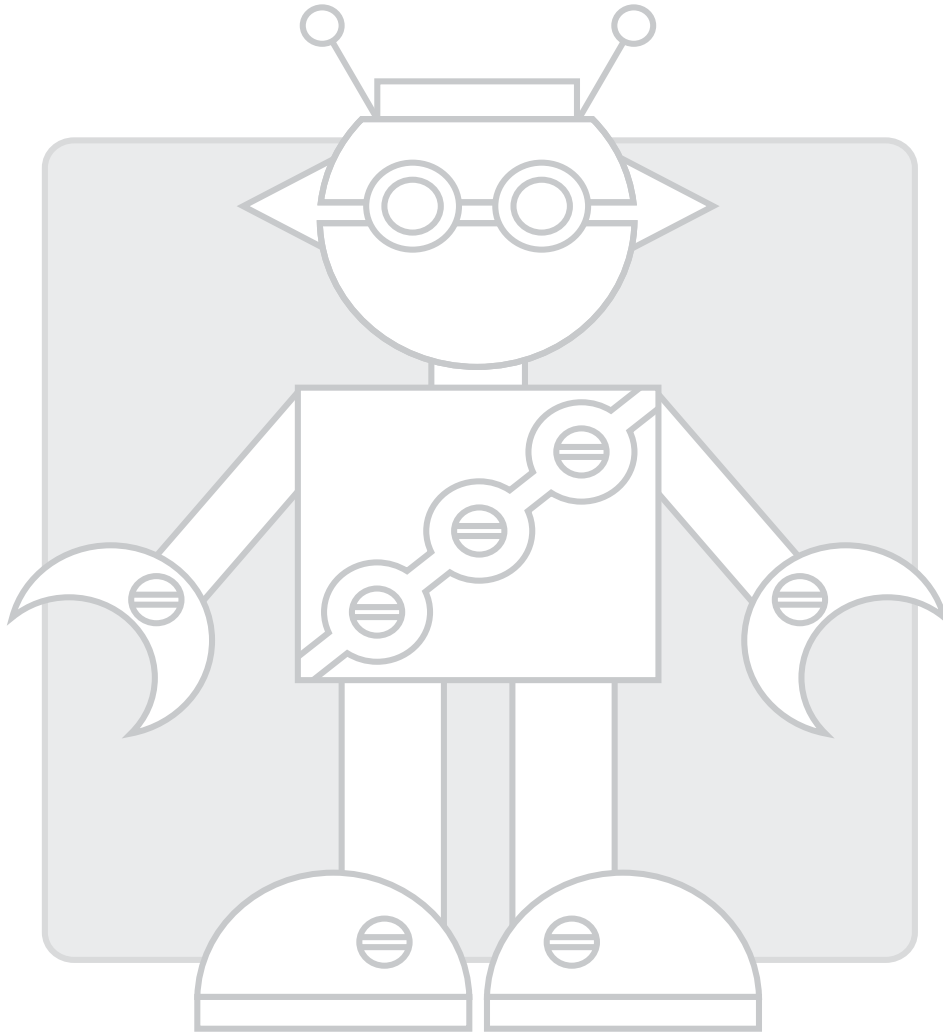

- ④ Haz 2 dibujos utilizando en cada uno de ellos líneas horizontales, verticales e inclinadas.

Unidad 4



Aprendamos la suma

Lección 1

Aprendamos a sumar

1 Suma agrupando los azulejos.

a) $3 + 1 =$

b) $2 + 2 =$

c) $1 + 1 =$

d) $1 + 4 =$

e) $1 + 2 =$

f) $2 + 1 =$

2 Suma.

a) $2 + 3 =$

b) $4 + 1 =$

c) $3 + 2 =$

3 Suma agrupando.

a)

 PO: $\underline{\quad} + \underline{\quad} = \underline{\quad}$
 R: $\underline{\hspace{2cm}}$

b)

 PO: $\underline{\quad} + \underline{\quad} = \underline{\quad}$
 R: $\underline{\hspace{2cm}}$

4 Suma agregando los azulejos.

a) $1 + 1 =$

b) $1 + 3 =$

c) $1 + 4 =$

d) $2 + 1 =$

e) $2 + 3 =$

f) $3 + 1 =$

5) Suma.

a) $2 + 2 =$

b) $2 + 3 =$

c) $3 + 1 =$

d) $2 + 1 =$

e) $1 + 1 =$

f) $4 + 1 =$

6) Suma agregando.

a)

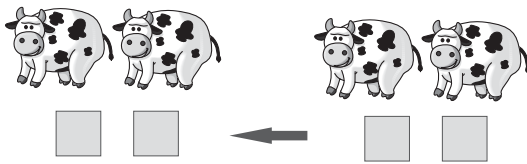

PO: _____

R: _____

b)

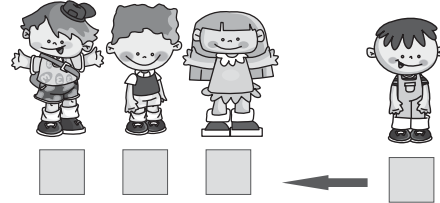

PO: _____

R: _____

7) Suma agrupando los azulejos.



$6 + 2 =$



$7 + 2 =$



$4 + 5 =$



$6 + 3 =$

8) Suma.

a) $5 + 4 =$

b) $7 + 1 =$

c) $3 + 5 =$

d) $2 + 6 =$

e) $6 + 1 =$

f) $2 + 6 =$

g) $3 + 6 =$

h) $3 + 3 =$

i) $1 + 8 =$

9 Resuelve.

a) ¿Cuántas naranjas hay en los dos árboles?

PO: _____ R: _____

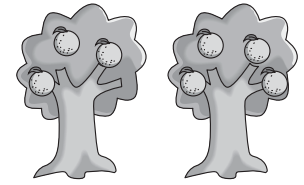

b) Luis tiene un caballo y una vaca.

¿Cuántas patas tiene entre los dos animales?

PO: _____ R: _____



c) El pastel de Gustavo tiene 3 velas y el de Silvio 6 velas.

¿Cuántas velas hay en los dos pasteles?

PO: _____ R: _____



10 Suma.

a) $7 + 2 =$

b) $4 + 5 =$

c) $3 + 4 =$

d) $6 + 3 =$

e) $5 + 2 =$

f) $8 + 1 =$

11 Resuelve.

a) Habían 4 arbolitos y se sembraron 3 más.

¿Cuántos arbolitos hay ahora?

PO: _____ R: _____

b) Rosa tenía 7 chibolas y Fredy le regaló 2.

¿Cuántas chibolas tiene Rosa ahora?

PO: _____ R: _____

c) Vilma tenía 5 guineos y Rosa le regaló 2.

¿Cuántos guineos tiene Vilma ahora?

PO: _____ R: _____

12 Suma.

$3 + 2 =$

$2 + 0 =$

$1 + 1 =$

$6 + 0 =$

$0 + 3 =$

$1 + 3 =$

$4 + 1 =$

$7 + 0 =$

$4 + 0 =$

$1 + 5 =$

$0 + 3 =$

$0 + 0 =$

$8 + 1 =$

$0 + 7 =$

$9 + 0 =$

Lección 2

Sigamos sumando

13 Suma.

a) $5 + 1 =$

b) $6 + 3 =$

c) $4 + 3 =$

$1 + 5 =$

$3 + 6 =$

$3 + 4 =$

d) $2 + 7 =$

e) $2 + 5 =$

f) $3 + 0 =$

$7 + 2 =$

$5 + 2 =$

$0 + 3 =$

14 Suma.

$2 + 1 =$

$4 + 3 =$

$5 + 0 =$

$6 + 2 =$

$3 + 5 =$

$4 + 1 =$

$0 + 7 =$

$1 + 8 =$

$3 + 3 =$

$5 + 4 =$

$6 + 3 =$

$2 + 7 =$

Nos divertimos

Ernesto compró 1 regalo y quiere pintarlo.
Hazlo según los resultados de las sumas.

Rojo = 9

Celeste = 8

Verde = 4

$6 + 2 =$

$1 + 3 =$

$7 + 2 =$

$5 + 4 =$

$2 + 7 =$

$3 + 1 =$

$2 + 6 =$

Unidad 5



Comencemos a restar

Lección 1

Aprendamos a restar

1 Resta.

a) $4 - 2 =$

b) $7 - 3 =$

c) $3 - 2 =$

d) $6 - 1 =$

2 Resta.

a)

 PO: _____
 R: _____

b)

 PO: _____
 R: _____

c)

 PO: _____
 R: _____

d)

 PO: _____
 R: _____

3 Resta.

$8 - 2 =$

$7 - 1 =$

$8 - 5 =$

$9 - 3 =$

$5 - 2 =$

$9 - 2 =$

$6 - 2 =$

$5 - 3 =$

$9 - 4 =$

$7 - 4 =$

$9 - 5 =$

$7 - 3 =$

4 Resuelve.

María tenía 9 chibolas y le regaló 2 a Juan.
¿Cuántas chibolas le quedan?

PO: _____

R: _____



5 Encuentra la diferencia.

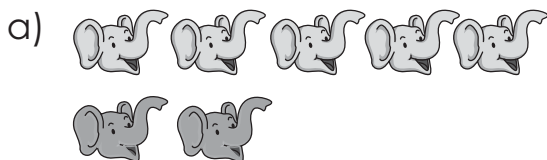

PO: _____

R: _____

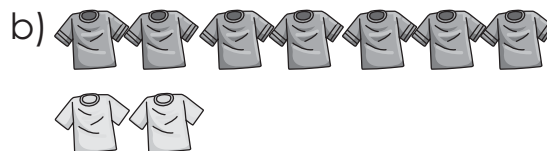

PO: _____

R: _____

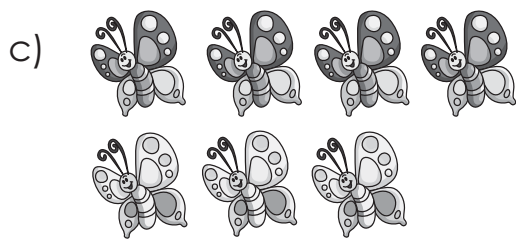

PO: _____

R: _____



PO: _____

R: _____

e)



PO: _____

R: _____

f)



PO: _____

R: _____

6) Resta.

$8 - 2 =$

$8 - 7 =$

$9 - 4 =$

$9 - 1 =$

$8 - 6 =$

$7 - 3 =$

$9 - 3 =$

$9 - 7 =$

$7 - 5 =$

$7 - 4 =$

$6 - 5 =$

$8 - 8 =$

7) Resuelve.

a) En la casa de Víctor hay 5 árboles. En la de Ana hay 1 árbol.
¿Cuántos árboles más hay en la casa de Víctor que en la de Ana?

PO: _____

R: _____



b) Carmen tiene 5 camisas y 4 faldas.
¿Cuántas camisas más que faldas tiene?

PO: _____

R: _____

8) Resta.

$8 - 1 =$

$4 - 1 =$

$9 - 3 =$

$2 - 2 =$

$7 - 0 =$

$6 - 6 =$

9) Resuelve.

a) En la casa de Víctor hay 5 árboles. En la de Ana no hay ningún árbol.
¿Cuántos árboles más hay en la casa de Víctor que en la de Ana?

PO: _____

R: _____

b) Doris tenía 4 dulces y regaló 4 a su hermana.
¿Cuántos dulces le quedan ahora?

PO: _____

R: _____

10) Resta.

$5 - 0 =$

$3 - 3 =$

$8 - 5 =$

$6 - 3 =$

$1 - 0 =$

$9 - 4 =$

$5 - 5 =$

$9 - 7 =$

$5 - 2 =$

$7 - 3 =$

$6 - 2 =$

$8 - 6 =$

Unidad 6



Descubramos las formas

Lección 2

Reconozcamos las formas de los objetos

1 Une con una línea los dibujos que tienen forma parecida.

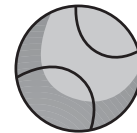
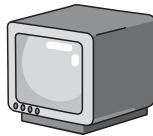

2 Contesta escribiendo las letras de cada objeto.

a)

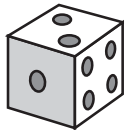

b)



c)



d)



e)



d)



¿Cuáles son los objetos que tienen forma de pelota? _____

¿Cuáles son los objetos que tienen forma de caja? _____

¿Cuáles son los objetos que tienen forma de lata? _____

③ Une con una línea la superficie de color con el nombre.

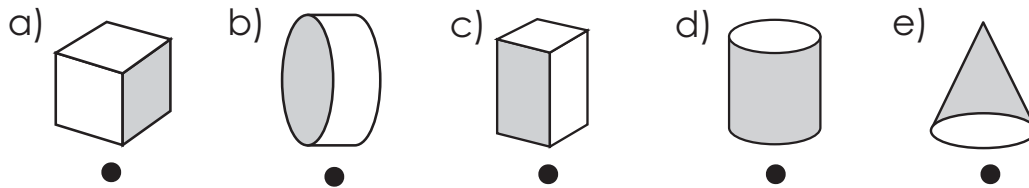

superficie plana

superficie curva

④ Escribe en el recuadro el nombre de cada parte.

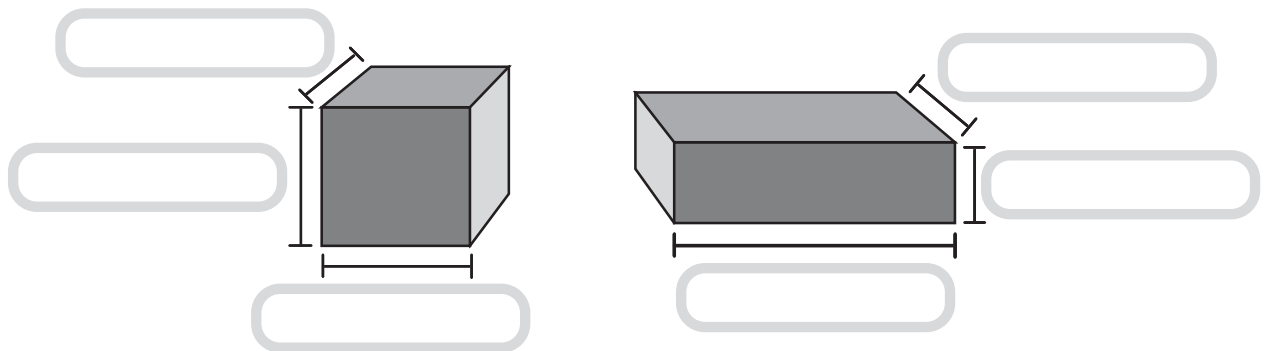

⑤ Une con una línea el objeto y el nombre de la forma.

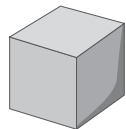

•

• Cilindro



•

• Esfera

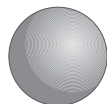

•

• Cubo

Unidad 7



Contemos hasta 19

Lección 1

Conozcamos el número 10

1 Cuenta y encierra los grupos que tienen 10 figuras.

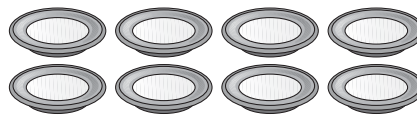
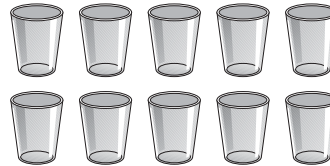
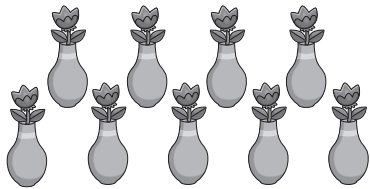

2 Colorea las marcas y escribe el número 10.

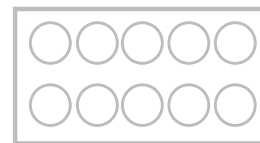
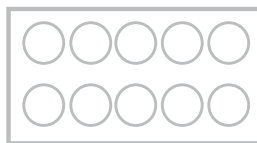
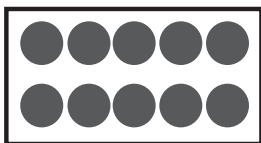
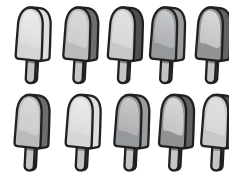
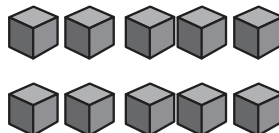

10

10

—

3 Escribe los números del 0 al 10.

0	1	2	3	4	5	6	7	8	9	10

4 Escribe en los cuadros el número de figuras y completa 10.

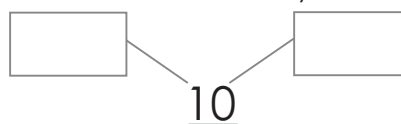
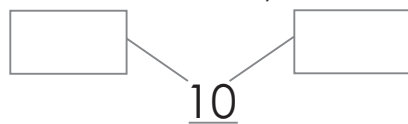
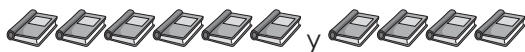
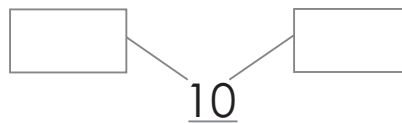
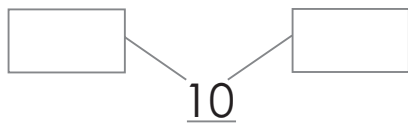

5 Escribe en los cuadros los números que faltan.

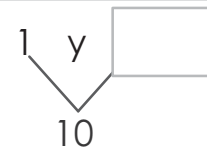
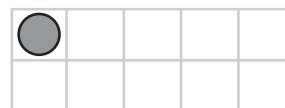
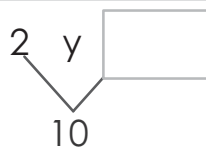
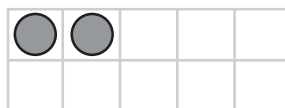
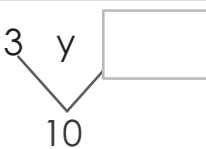
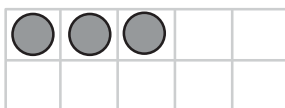
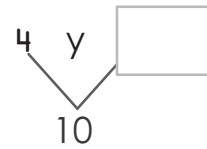
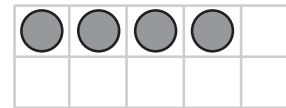
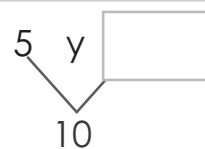
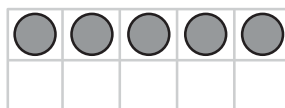
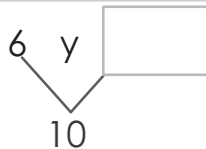
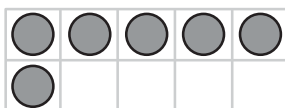
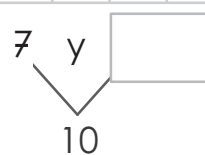
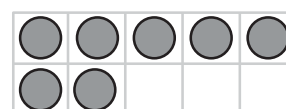
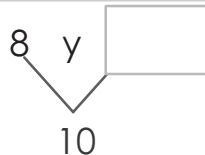
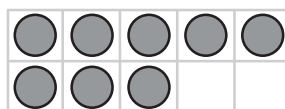
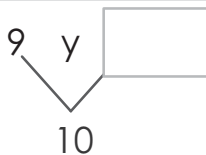
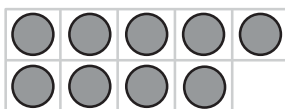

6) ¿Cuántos azulejos hay en cada caja para completar 10?

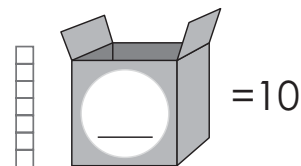
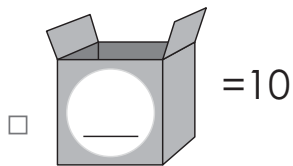
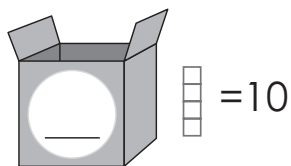
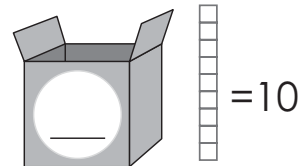
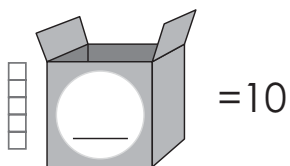
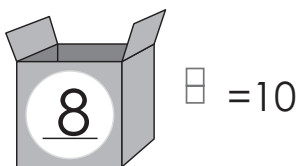

7) Escribe el número que falta para completar el 10.

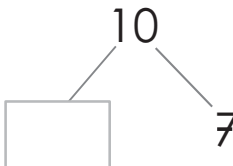
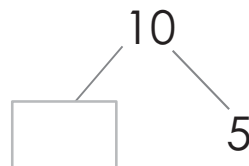
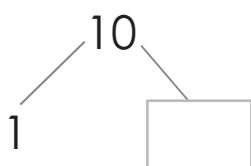
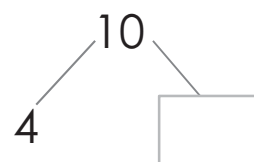
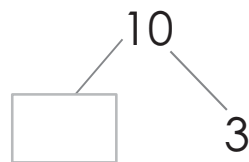
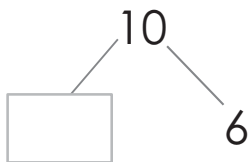
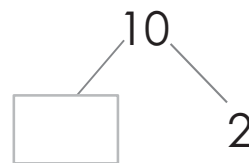
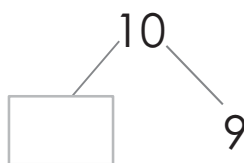
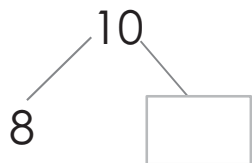

8) Escribe el PO.

a) Ejemplo.

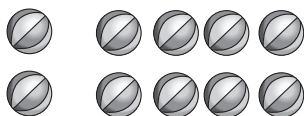

PO: $2 + 8 = 10$

b)



c)



d)



e)



f)



9 Encuentra el número que falta para formar 10.

$3 + \square = 10$

$5 + \square = 10$

$\square + 9 = 10$

$\square + 1 = 10$

$\square + 3 = 10$

$2 + \square = 10$

$\square + 6 = 10$

$8 + \square = 10$

$4 + \square = 10$

Lección 2 Formemos decenas

10 Cuenta y escribe los números en las tablas de valores.

a)



D	U

_____ decena y _____ unidades

son _____ .

Se lee _____ .

b)



D	U

_____ decena y _____ unidades

son _____ .

Se lee _____ .

c)

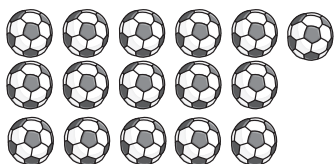

D	U

_____ decena y _____ unidades

son _____ .

Se lee _____ .

d)

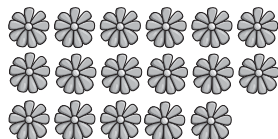

D	U

_____ decena y _____ unidades

son _____ .

Se lee _____ .

11 Cuenta y escribe los números en la tabla de valores.

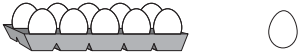

_____ y _____

D	U



_____ y _____

D	U



_____ y _____

D	U

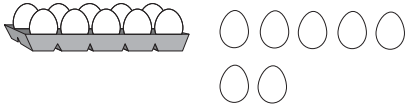

_____ y _____

D	U



_____ y _____

D	U

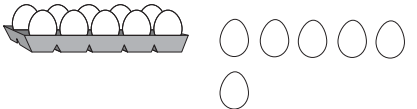

_____ y _____

D	U

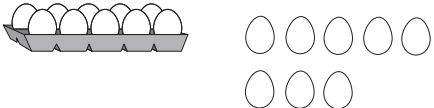

_____ y _____

D	U

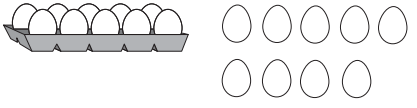

_____ y _____

D	U

12 Escribe el número en cada tabla de valores.

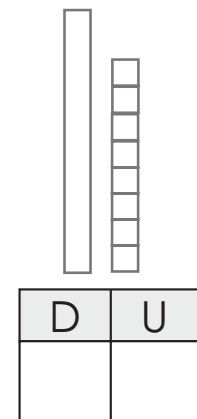
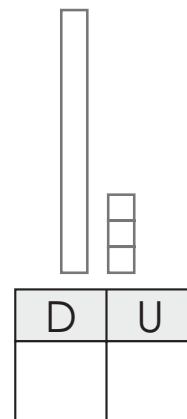
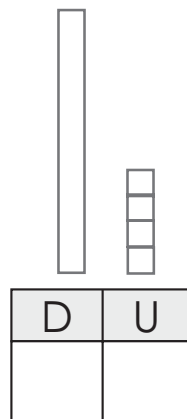
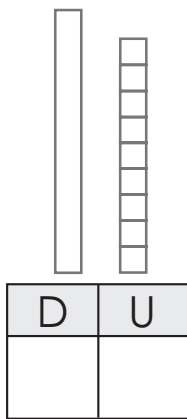
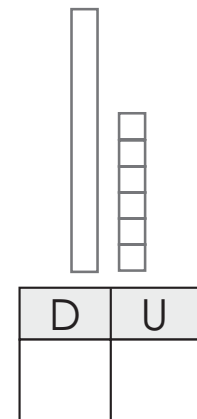
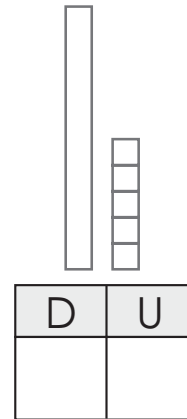
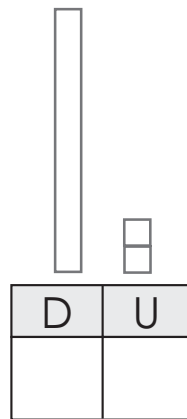
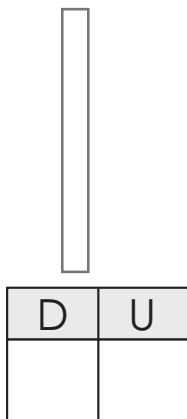
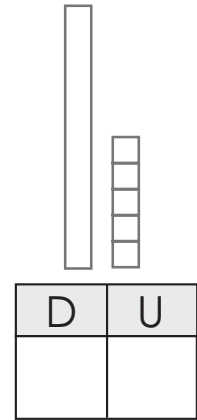
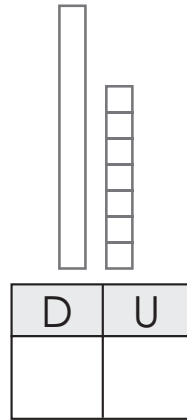
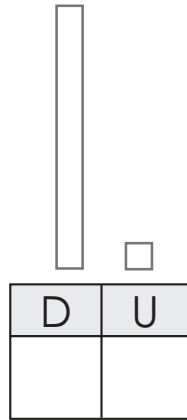
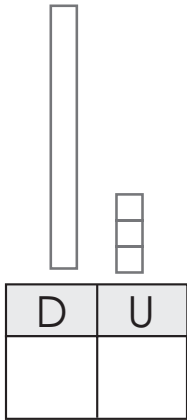

13) Escribe los números que faltan.



14) Señala con una flecha. Sigue el ejemplo.

a) 10

b) 7 más que 10

c) 5 menos que 10

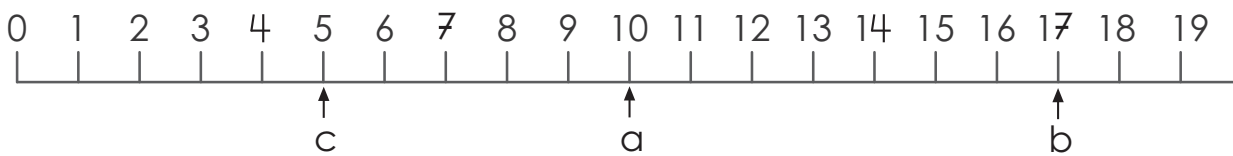

a) 7

b) 8 más que 7

c) 3 menos que 7

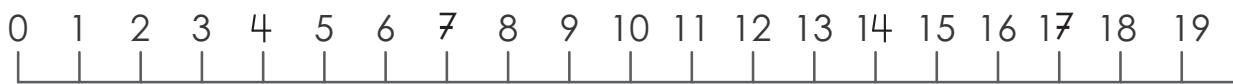

a) 14

b) 4 más que 14

c) 9 menos que 14



15 Completa las secuencias de números.

a)

2		4				8	9		11			14			17	
---	--	---	--	--	--	---	---	--	----	--	--	----	--	--	----	--

3		5		7		9		11		13		15		17		19
---	--	---	--	---	--	---	--	----	--	----	--	----	--	----	--	----

3			6		8	9		11		13	14		16		18	19
---	--	--	---	--	---	---	--	----	--	----	----	--	----	--	----	----

	11		13	14		16		18	19
--	----	--	----	----	--	----	--	----	----

8			11		13			16		18	
---	--	--	----	--	----	--	--	----	--	----	--

b)

19		17		15		13		11		9		7		5		
----	--	----	--	----	--	----	--	----	--	---	--	---	--	---	--	--

18		16		14	13				9	8		6			3	
----	--	----	--	----	----	--	--	--	---	---	--	---	--	--	---	--

	18		16				12					8				3
--	----	--	----	--	--	--	----	--	--	--	--	---	--	--	--	---

10		8		6		4		2	
----	--	---	--	---	--	---	--	---	--

15			12			9			6	5	
----	--	--	----	--	--	---	--	--	---	---	--

16 Marca con una "X", en cada grupo.

a) El número mayor.

(11,16)

(10,8)

(15,13,18)

a) El número menor.

(13,15)



(11,9)

(16,14,18)

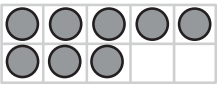

Lección 3

Hagamos otras sumas

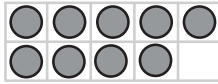

17 Suma completando la decena.

a)  + 

$$8 + 4 = \square$$

b)  + 



$$9 + 7 = \square$$

c)  + 

$$5 + 6 =$$

d)  + 

$$4 + 8 =$$

e)  + 

$$2 + 8 =$$

f)  + 

$$7 + 9 =$$

18 Suma.

a) $3 + 9 = \square$

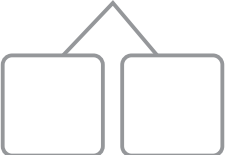

b) $4 + 8 = \square$

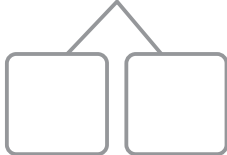

c) $9 + 4 = \square$

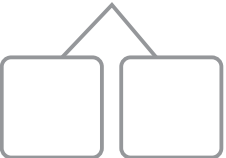

d) $5 + 9 = \square$



e) $5 + 7 = \square$

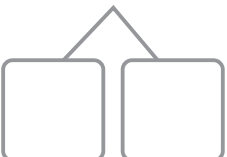

f) $7 + 7 = \square$

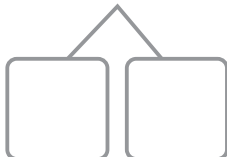

19 Suma.

$9 + 5 =$

$8 + 6 =$

$3 + 9 =$

$6 + 7 =$

$8 + 8 =$

$8 + 5 =$

$6 + 9 =$

$7 + 7 =$

$6 + 6 =$

$5 + 7 =$

$4 + 9 =$

$2 + 9 =$

20 Suma.

$9 + 3 =$

$4 + 7 =$

$8 + 3 =$

$7 + 8 =$

$9 + 7 =$

$3 + 9 =$

$5 + 9 =$

$7 + 4 =$

$9 + 1 =$

$9 + 4 =$

$7 + 5 =$

$9 + 9 =$

21 Resuelve.

a) Si en mi casa hay 4 gallinas y 9 pollos,
¿Cuántas aves hay?

PO: _____ R: _____

b) Luis tiene 8 chibolas y Carlos le regala 9.
¿Cuántas chibolas tiene?

PO: _____ R: _____

¡Qué divertido es resolver problemas!



22 Suma a 8 y a 6, los números que les rodean.
Escribe los resultados en cada cuadro.

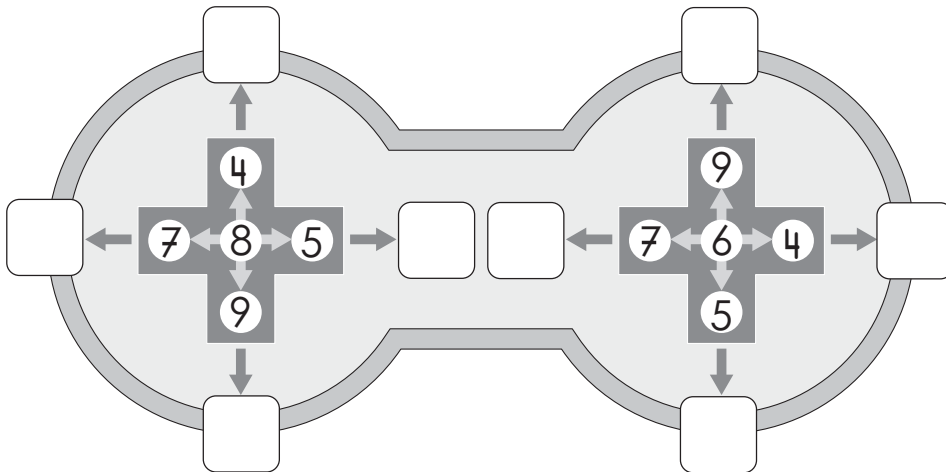

23 Suma en forma vertical.

a)
$$\begin{array}{r} 7 \\ + 5 \\ \hline \end{array}$$

b)
$$\begin{array}{r} 8 \\ + 6 \\ \hline \end{array}$$

c)
$$\begin{array}{r} 9 \\ + 2 \\ \hline \end{array}$$

d)
$$\begin{array}{r} 9 \\ + 6 \\ \hline \end{array}$$

e)
$$\begin{array}{r} 4 \\ + 7 \\ \hline \end{array}$$

f)
$$\begin{array}{r} 3 \\ + 9 \\ \hline \end{array}$$

g)
$$\begin{array}{r} 6 \\ + 7 \\ \hline \end{array}$$

h)
$$\begin{array}{r} 8 \\ + 8 \\ \hline \end{array}$$

24 Resuelve en forma vertical.

a) José tiene 4 carritos y 8 pelotas.
¿Cuántos juguetes tiene?

PO: _____ R: _____

Cálculo

+		

Cálculo

+		

b) Karla tenía 5 pollitos y su mamá le regaló 7.
¿Cuántos pollitos tiene ahora?

PO: _____ R: _____

Lección 4 Continuemos sumando

25 Suma.

a) $13 + 4$

+		

b) $7 + 12$

+		

c) $12 + 6$

+		

d) $4 + 13$

+		

26 Suma.

a)

	1	4
+		3

b)

	1	0
+		9

c)

	1	4
+		4

d)

	1	5
+		4

e)

		1
+	1	8

f)

		5
+	1	2

g)

		2
+	1	6

h)

		6
+	1	3

27) Suma en forma vertical.

a) $14 + 5$

b) $3 + 16$

c) $11 + 8$

d) $7 + 12$

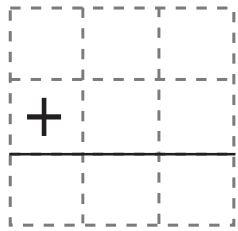

28) Suma el número del centro con los que lo rodean. Escribe los resultados en el recuadro.

a)

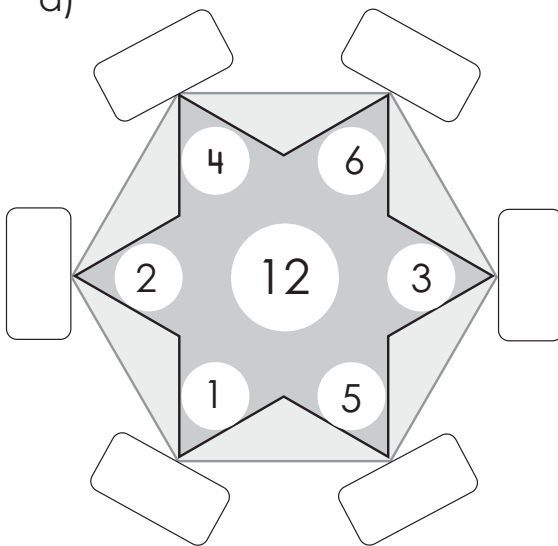

b)

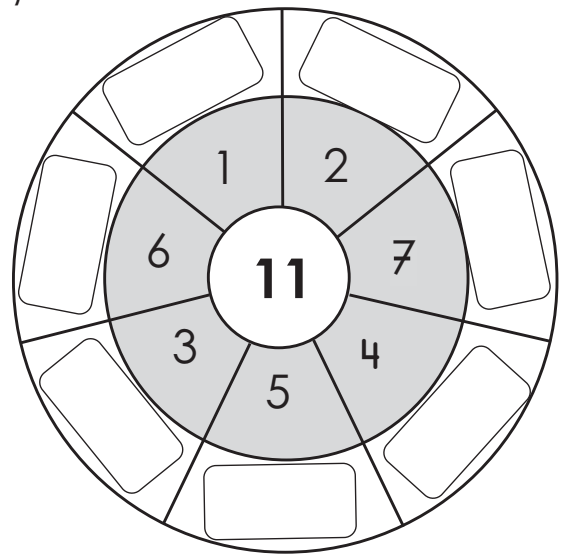

29) Suma en la recta numérica.

a) $6 + 8$



b) $5 + 13$





Nos divertimos

¿Qué está escondido?

Encuentra la respuesta de la suma.

Pinta las casillas de la derecha que tienen el mismo número de la respuesta.

¿Qué aparece?

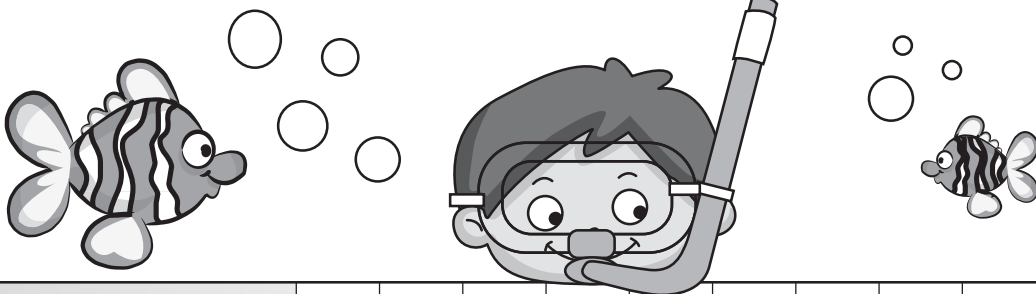

$6 + 3 =$	7	8	8	9	9	9	8	8	7	7	8
$4 + 4 =$	9	9	8	8	8	8	8	6	6	9	9
$5 + 5 =$	10	10	10	9	10	10	10	10	9	11	11
$2 + 7 =$	8	8	8	9	9	10	9	9	10	11	11
$8 + 3 =$	12	12	12	11	10	10	11	11	12	12	10
$4 + 9 =$	11	11	13	13	14	13	13	13	13	11	11
$6 + 6 =$	16	16	12	14	14	12	12	12	12	11	11
$8 + 5 =$	14	14	13	15	15	13	13	13	13	12	12
$2 + 9 =$	13	11	11	12	12	11	11	11	11	11	12
$4 + 6 =$	14	10	14	14	14	10	10	10	10	10	11
$6 + 9 =$	16	15	16	14	14	15	15	15	15	15	16
$8 + 8 =$	18	16	14	14	18	16	16	16	16	16	18
$6 + 7 =$	15	13	13	13	12	12	12	13	13	13	14
$7 + 5 =$	10	10	12	12	11	11	13	12	12	12	13
$6 + 8 =$	15	15	15	14	14	14	14	14	14	14	14
$9 + 3 =$	13	13	12	12	12	12	13	13	11	11	11

30 Resta.

a) Escribe en la línea de abajo el PO que se representa con los azulejos.

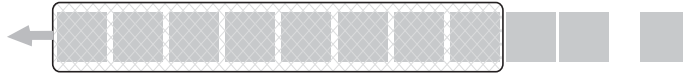

PO: _____

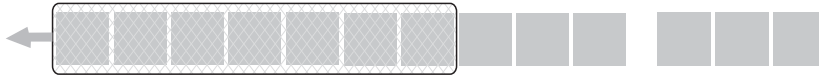

PO: _____



PO: _____

b) Resta utilizando azulejos y descomponiendo la primera cantidad.

$$14 - 6 =$$

$$12 - 7 =$$

$$15 - 9 =$$

31 Resta descomponiendo la primera cantidad.

a) $11 - 3 = \square$

b) $13 - 5 = \square$

c) $11 - 4 = \square$

d) $13 - 4 = \square$

e) $12 - 5 = \square$

f) $12 - 3 = \square$

32 Resta.

$15 - 6 =$

$14 - 9 =$

$17 - 8 =$

$14 - 5 =$

$16 - 7 =$

$12 - 3 =$

$10 - 6 =$

$12 - 9 =$

$13 - 6 =$

$11 - 7 =$

$14 - 8 =$

$13 - 9 =$

33 Resta.

$15 - 8 =$

$12 - 4 =$

$18 - 9 =$

$12 - 6 =$

$17 - 9 =$

$13 - 5 =$

$11 - 6 =$

$12 - 8 =$

$11 - 8 =$

$15 - 9 =$

$14 - 7 =$

$11 - 9 =$

34 Resuelve.

a) En el aula hay 14 estudiantes, 7 son niños.

¿Cuántas niñas hay?

PO: _____ **R:** _____

b) En el salón hay 12 pupitres entre buenos y malos, 9 están buenos.

¿Cuántos pupitres malos hay?

PO: _____ **R:** _____

35 Resta.

$$\begin{array}{r} 15 \\ - 7 \\ \hline \end{array}$$

$$\begin{array}{r} 17 \\ - 8 \\ \hline \end{array}$$

$$\begin{array}{r} 18 \\ - 9 \\ \hline \end{array}$$

$$\begin{array}{r} 15 \\ - 6 \\ \hline \end{array}$$

$$\begin{array}{r} 14 \\ - 5 \\ \hline \end{array}$$

$$\begin{array}{r} 16 \\ - 8 \\ \hline \end{array}$$

$$\begin{array}{r} 13 \\ - 4 \\ \hline \end{array}$$

$$\begin{array}{r} 16 \\ - 7 \\ \hline \end{array}$$

36 Resuelve.

a) Hay 15 tortillas. Si Elena se come 7, ¿cuántas quedan?

PO: _____ **R:** _____

b) Flor tiene 12 globos de color rojo y 3 de color verde.

¿Cuántos globos rojos más que verdes tiene?

PO: _____ **R:** _____

37 Resta en la recta numérica.

a) $15 - 9$

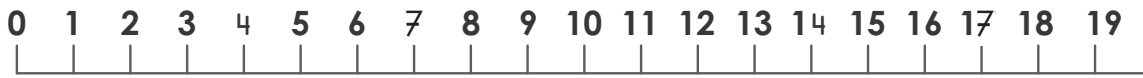

b) $17 - 6$



c) $12 - 8$

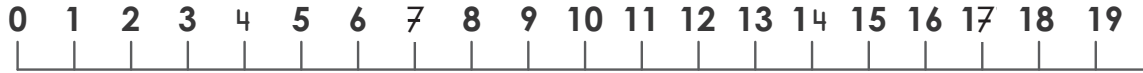

38 Resta al número del centro los números que están alrededor y escribe las respuestas en los recuadros.

a)

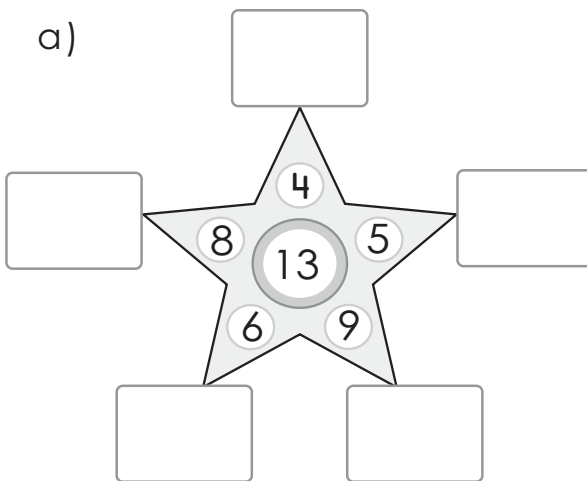

b)

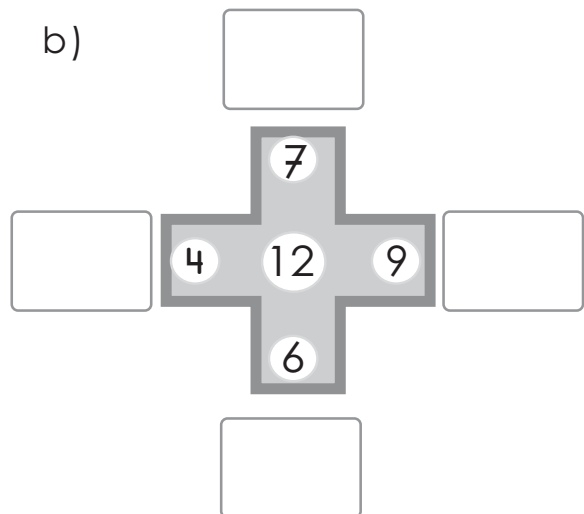

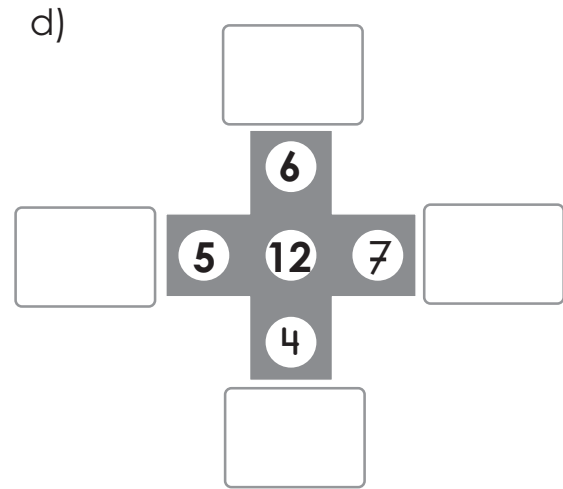
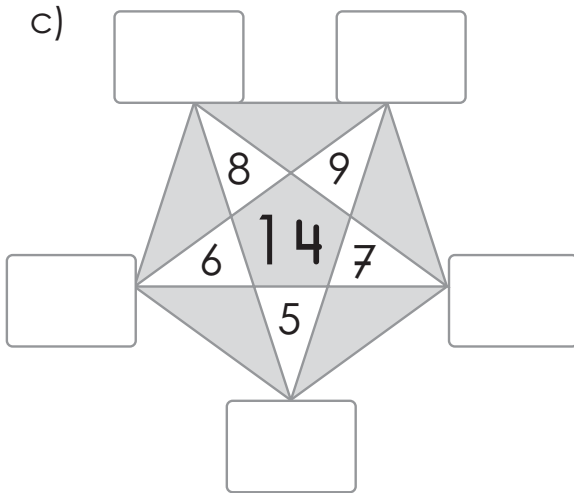

39 Resta.

$11 - 3$

—		
—		

$12 - 3$

—		
—		

$12 - 5$

—		
—		

$14 - 5$

—		
—		

$15 - 8$

—		
—		

$12 - 7$

—		
—		

$13 - 9$

—		
—		

$15 - 6$

—		
—		

$16 - 8 =$

$14 - 6 =$

$12 - 7 =$

$18 - 9 =$

- 40 Resta, al número del centro, los números que le rodean y escribe las respuestas donde corresponda.

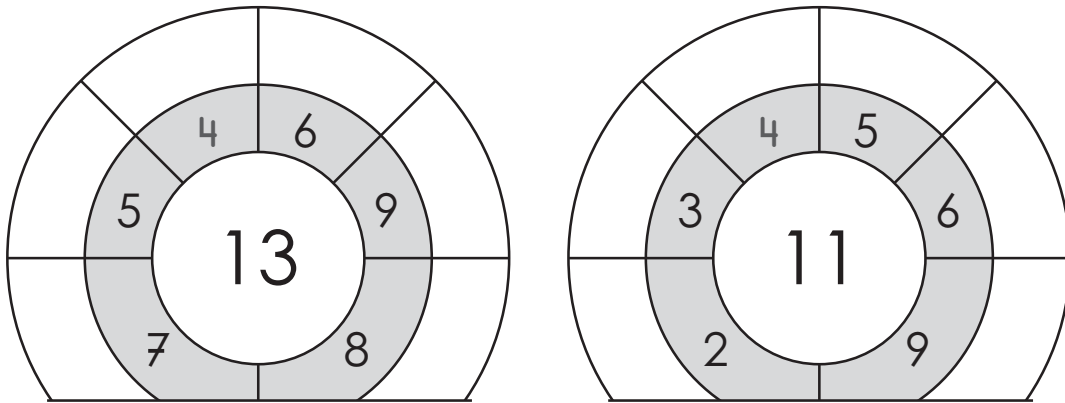

- 41 Resuelve.

a) Carlos compró 15 mangos y se comió 6.

¿Cuántos le quedan?

PO: _____ R: _____

b) Vilma tiene 12 chibolas de color verde y 8 de color rojo.

¿Cuántas chibolas verdes más que rojas tiene?

PO: _____ R: _____

a) En la bodega hay 17 piñas, 9 están maduras.

¿Cuántas piñas sin madurar hay?

PO: _____ R: _____

Unidad 8



Conozcamos figuras

Lección 1

Conozcamos las figuras planas

1 Une con una línea la figura y el objeto que contiene la figura parecida.

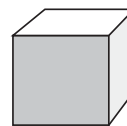
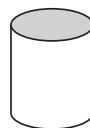
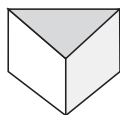
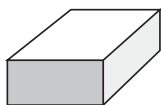
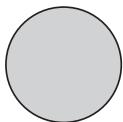

2 Escribe el nombre de las figuras.



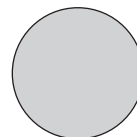



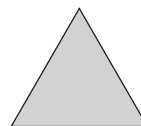

3 Contesta.

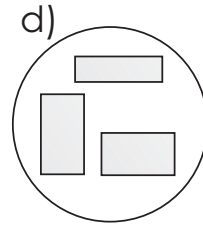
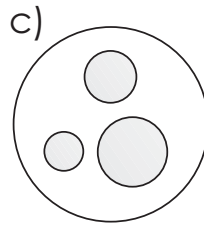
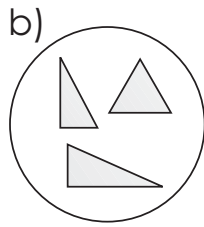
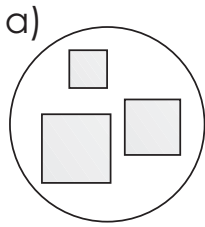

¿Cuál es el grupo de círculos?

¿Cuál es el grupo de triángulos?

¿Cuál es el grupo de rectángulos?

¿Cuál es el grupo de cuadrados?

4 Escribe en las líneas los números de la figura.

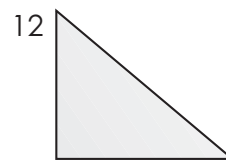
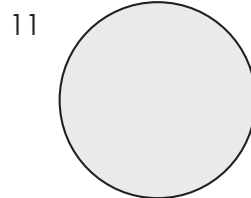
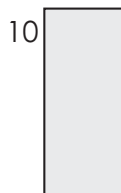
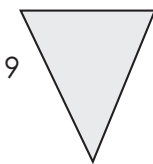
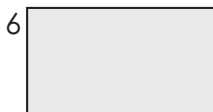
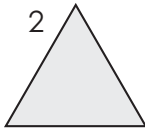

Cuadrados: _____

Rectángulos: _____

Triángulos: _____

Círculos: _____

5 Dibuja las figuras.

- a) Dibuja ○ en el borde.
- b) Dibuja × en la parte exterior.
- c) Dibuja △ en la parte interior.

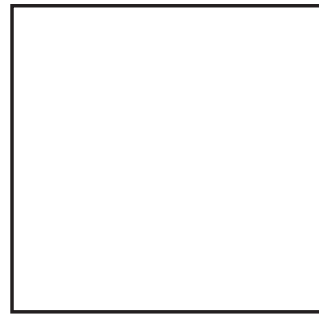

Lección 2 Dibujemos utilizando figuras planas

6 Calca varias veces las figuras y construye los siguientes objetos.

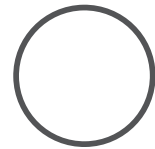
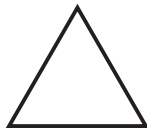
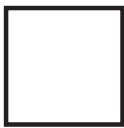

a) una casa

b) un niño

c) un vehículo

Unidad 9



Sumemos y restemos hasta 99

Lección 1

Aprendamos los números hasta 99

1 ¿Cómo se escribe en números?

a) Una decena y nueve unidades. _____

b) Dos decenas y cinco unidades. _____

c) Tres decenas y tres unidades. _____

2 Escribe el número en cada tabla de valores.

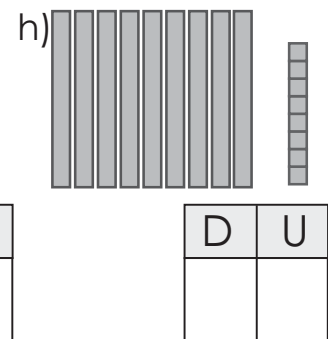
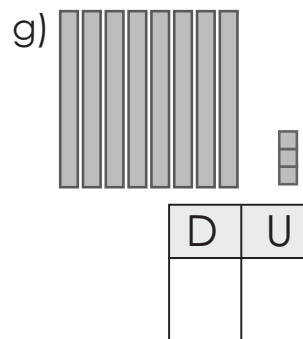
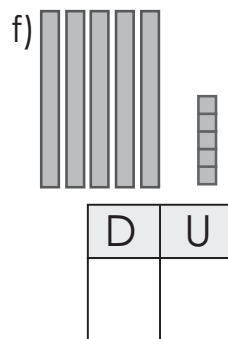
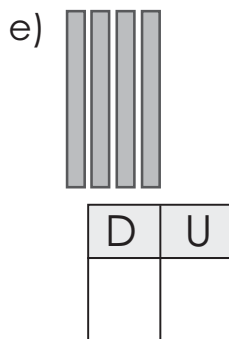
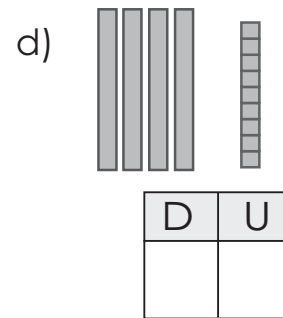
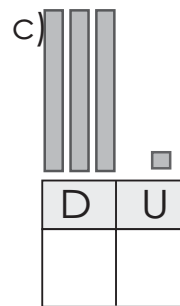
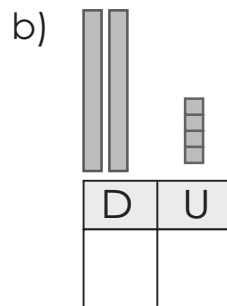
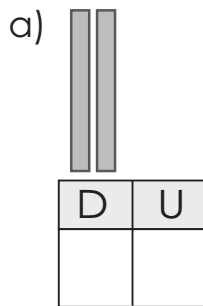

3) Escribe la cantidad.

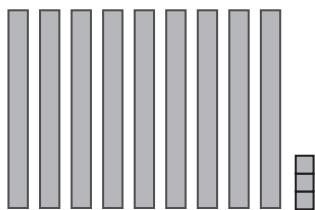

decenas y unidades son

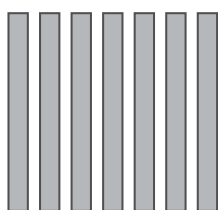

decenas y unidades son

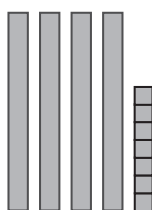

decenas y unidades son

4) Escribe.

a) El número formado por 8 decenas

b) El número formado por 4 decenas y 8 unidades

c) El número formado por 3 decenas y 1 unidad

d) El número formado por 1 decena y 9 unidades

5) Escribe las decenas y unidades.

- a) 74 → decenas y unidades
- b) 92 → decenas y unidades
- c) 29 → decenas y unidades
- d) 66 → decenas y unidades
- e) 20 → decenas y unidades
- f) 42 → decenas y unidades
- g) 97 → decenas y unidades

6) Coloca el número y escribe el nombre.

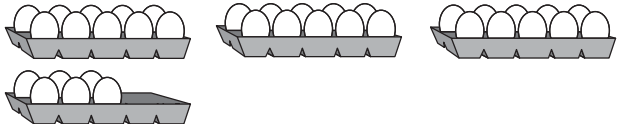
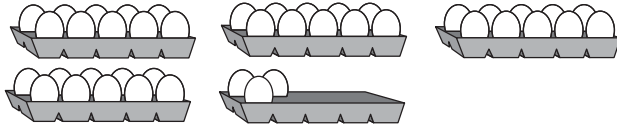
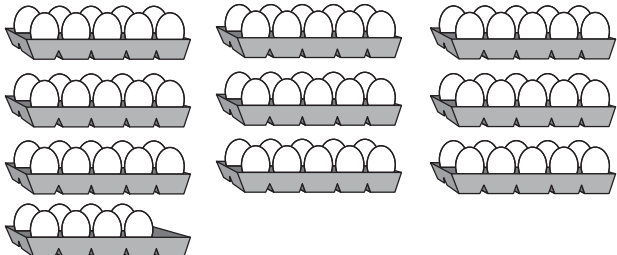
cantidad	número	lectura
		
		
		
		

7 Indica los números en la recta, como el ejemplo.

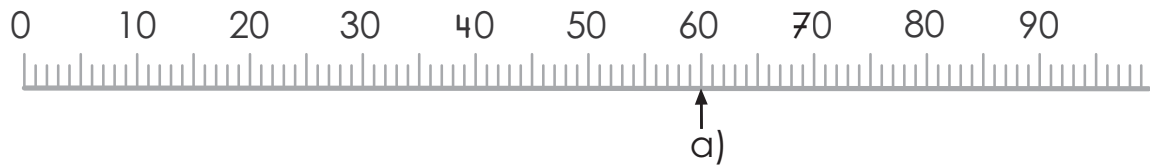

- a) El número 60
- b) El número que es 4 más que 60
- c) El número que es 1 más que 20
- d) El número 84
- e) El número que es 4 menos que 84
- f) El número que es 4 menos que 84
- g) El número que es 6 menos que 78

8 Indica los números en la recta.

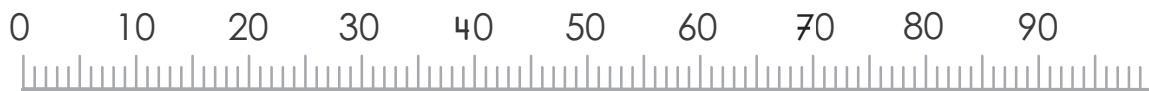

- a) El número que es 3 más que 31
- b) El número que es 2 menos que 55
- c) El número que es 5 más que 68
- d) El número que es 7 menos que 94

9 Escribe los números que faltan.

a)

10	—	11	—	□	—	13	—	14	—	□	—	□	—	17
67	—	□	—	69	—	70	—	□	—	72	—	□	—	74
80	—	□	—	82	—	□	—	84	—	□	—	86	—	□
48	—	□	—	50	—	□	—	52	—	□	—	54	—	□
□	—	37	—	□	—	39	—	□	—	41	—	□	—	43
89	—	□	—	91	—	□	—	93	—	□	—	95	—	□

b)

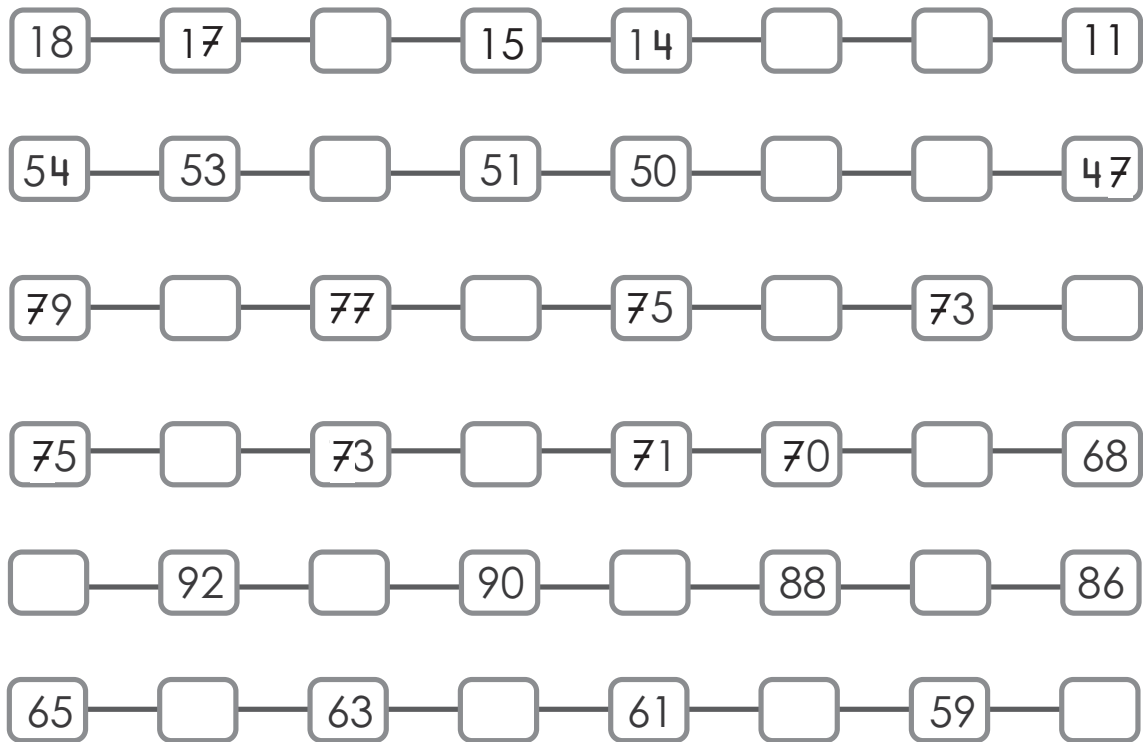

10 Encierra el número mayor de cada pareja.

- | | | | | | |
|----|----|----|----|----|----|
| 15 | 36 | 16 | 28 | 15 | 30 |
| 5 | 7 | 19 | 31 | 27 | 16 |
| 12 | 32 | 13 | 26 | 14 | 28 |
| 17 | 26 | 16 | 32 | 15 | 17 |
| 46 | 36 | 40 | 50 | 50 | 30 |
| 40 | 39 | 29 | 37 | 42 | 52 |
| 49 | 47 | 59 | 54 | 34 | 54 |
| 37 | 34 | 41 | 51 | 76 | 65 |
| 76 | 54 | 76 | 62 | 78 | 61 |

Lección 3

Contemos por grupos

11 Cuenta.

a)

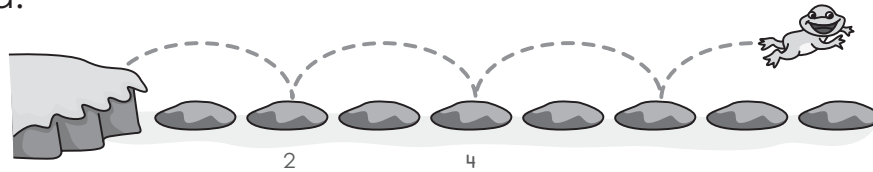

Las piedras de _____ en _____. Hay _____ piedras.

b)

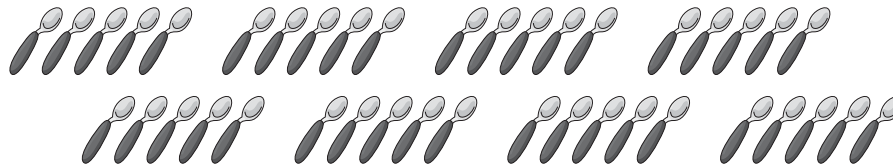

Las cucharas de _____ en _____. Hay _____ cucharas.

12 Escribe los números contando de 2 en 2; de 5 en 5 y de 10 en 10.

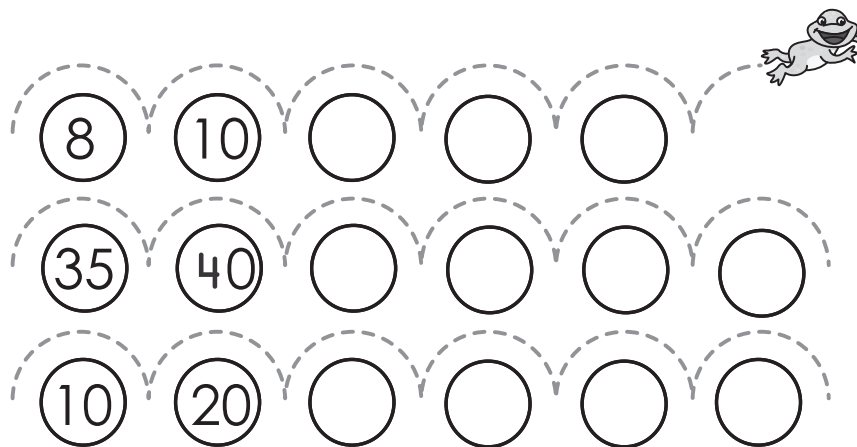

13 Cuenta por grupo y escribe el número de objetos.

a)



b)



14 Completa los números que faltan.

72	74		78		82		86	
20		30		40		50		60
10		30		50		70		

Nos divertimos

Une los puntos contando de dos en dos.

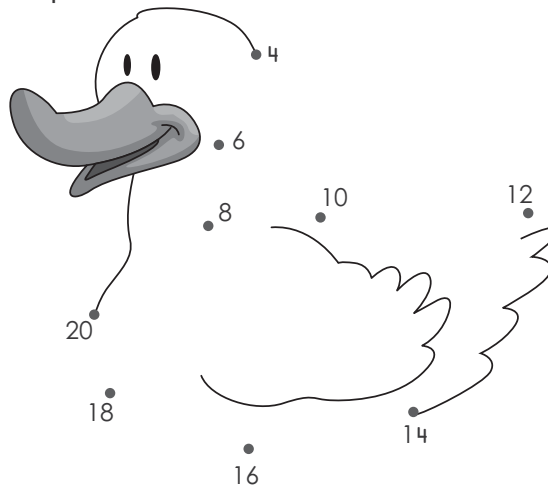

Une los puntos contando de 5 en 5.

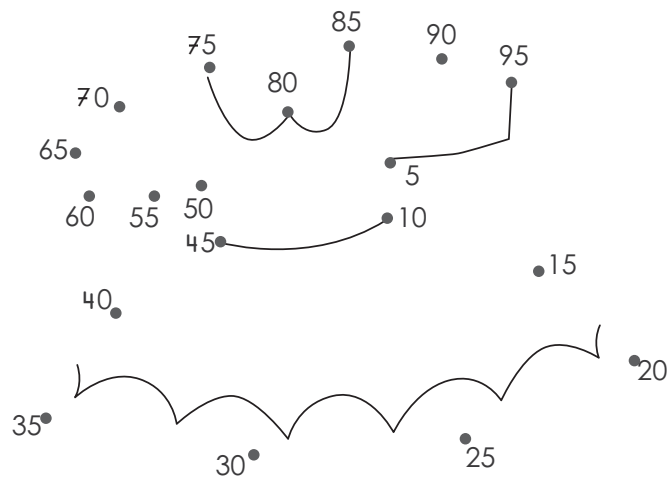

Lección 4

Hagamos otras sumas

15 Suma.

a) $20 + 50 =$ b) $10 + 80 =$ c) $30 + 60 =$ d) $40 + 50 =$

16 Resuelve.

Rosa tiene 30 chibolas y su papá le regala 20. ¿Cuántas tiene ahora?

PO: _____

R: _____

17 Suma.

a) $20 + 7 =$ b) $50 + 8 =$ c) $80 + 9 =$ d) $70 + 6 =$

18 Resuelve.

Jorge tiene 30 elotes y compra 8. ¿Cuántos tiene?

PO: _____

R: _____

19 Suma.

a) $8 + 40 =$ b) $6 + 90 =$ c) $7 + 30 =$ d) $9 + 70 =$

Lección 5

Sigamos sumando

20 Suma en forma vertical.

a) $12 + 46$

b) $55 + 32$

c) $22 + 63$

d) $76 + 21$

	1	2
+	4	6
<hr/>		

+		
<hr/>		

+		
<hr/>		

+		
<hr/>		

e) $26 + 13$

+		
<hr/>		

f) $15 + 62$

+		
<hr/>		

g) $28 + 11$

+		
<hr/>		

h) $64 + 32$

+		
<hr/>		

21 Suma en forma vertical.

a) $54 + 3$

b) $22 + 6$

c) $35 + 4$

d) $46 + 2$

+		
<hr/>		

e) $64 + 3$

f) $77 + 2$

g) $45 + 3$

h) $46 + 2$

22 Suma en forma vertical.

a) $4 + 55$

b) $2 + 64$

c) $5 + 43$

d) $3 + 26$

+		
<hr/>		

e) $2 + 87$

f) $7 + 42$

g) $3 + 76$

h) $2 + 87$

23 Resuelve.

a) En el aula hay 18 niños y 21 niñas.

¿Cuántos hay en total?

PO: _____ R: _____

Cálculo

b) Pablo tiene 35 chibolas y compra 20 más.

¿Cuántas chibolas tiene Pablo ahora?

PO: _____ R: _____

Cálculo

Lección 6 Sumemos llevando

24 Suma en forma vertical.

$$\begin{array}{r} 18 \\ + 45 \\ \hline \end{array}$$

$$\begin{array}{r} 27 \\ + 54 \\ \hline \end{array}$$

$$\begin{array}{r} 69 \\ + 16 \\ \hline \end{array}$$

$$\begin{array}{r} 77 \\ + 14 \\ \hline \end{array}$$

$$\begin{array}{r} 56 \\ + 25 \\ \hline \end{array}$$

$$\begin{array}{r} 39 \\ + 45 \\ \hline \end{array}$$

$$\begin{array}{r} 14 \\ + 48 \\ \hline \end{array}$$

$$\begin{array}{r} 69 \\ + 27 \\ \hline \end{array}$$

$36 + 17$

$47 + 38$

$63 + 19$

$28 + 54$

+		

$15 + 76$

$29 + 57$

$33 + 49$

$48 + 28$

25 Suma.

$$\begin{array}{r} 64 \\ + 26 \\ \hline \end{array}$$

$$\begin{array}{r} 43 \\ + 47 \\ \hline \end{array}$$

$$\begin{array}{r} 22 \\ + 58 \\ \hline \end{array}$$

$$\begin{array}{r} 41 \\ + 39 \\ \hline \end{array}$$

$65 + 25$

$18 + 72$

$37 + 13$

$54 + 36$

+		
<hr/>		

26 Suma en forma vertical.

 $34 + 7$

+		
<hr/>		

$47 + 5$

$69 + 3$

$36 + 5$

$26 + 4$

$67 + 3$

$5 + 28$

$7 + 36$

$6 + 49$

$7 + 87$

$9 + 71$

$5 + 35$

27 Inventa problema del PO: $27 + 18$

PO:
R:

Cálculo

--

28 Suma los números del centro hacia afuera.
Escribe las respuestas en los cuadros.

a)

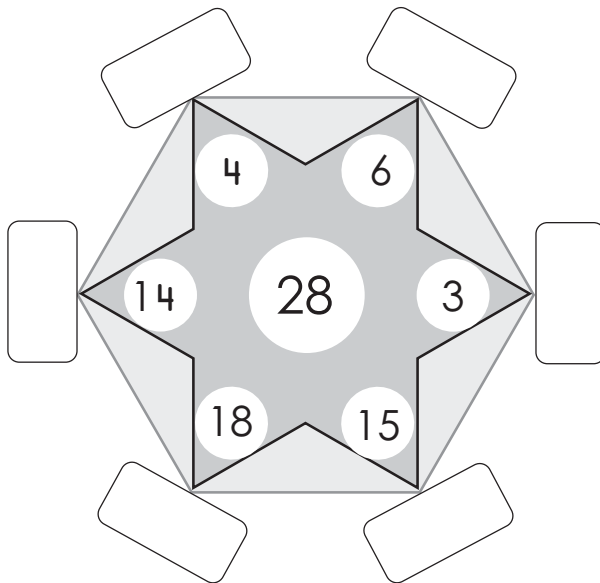

b)

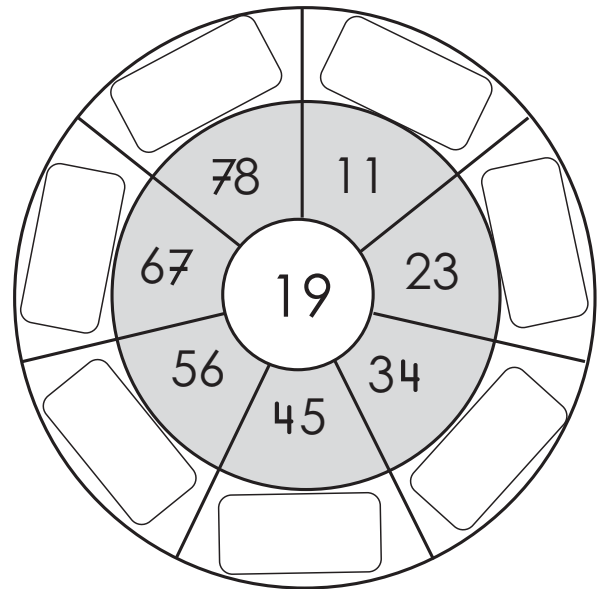

Nos divertimos

¿Quieres encontrar las frutas?

- Haz todas las operaciones.
- Sigue los resultados de menor a mayor.
- Marca la ruta utilizando lápiz de color.

Entrada
↓

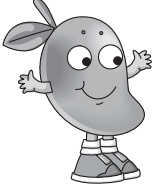
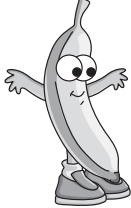
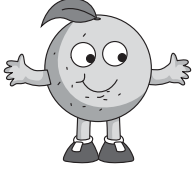
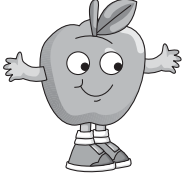
	$\begin{array}{r} 20 \\ + 10 \\ \hline \end{array}$	$\begin{array}{r} 18 \\ + 9 \\ \hline \end{array}$	
$\begin{array}{r} 4 \\ + 35 \\ \hline \end{array}$	$\begin{array}{r} 22 \\ + 14 \\ \hline \end{array}$	$\begin{array}{r} 37 \\ + 38 \\ \hline \end{array}$	$\begin{array}{r} 54 \\ + 29 \\ \hline \end{array}$
$\begin{array}{r} 40 \\ + 8 \\ \hline \end{array}$	$\begin{array}{r} 26 \\ + 32 \\ \hline \end{array}$	$\begin{array}{r} 4 \\ + 67 \\ \hline \end{array}$	$\begin{array}{r} 35 \\ + 54 \\ \hline \end{array}$
	$\begin{array}{r} 51 \\ + 9 \\ \hline \end{array}$	$\begin{array}{r} 42 \\ + 22 \\ \hline \end{array}$	

Lección 7

Restemos

29 Resta.

a) $30 - 20 =$

b) $70 - 50 =$

c) $40 - 10 =$

d) $80 - 30 =$

30 Resuelve.

Pedro tiene 40 dulces y regala 30 a sus amigos. ¿Cuántos le quedan?

PO: _____

R: _____

31 Resta.

a) $28 - 20 =$

b) $37 - 30 =$

c) $57 - 50 =$

d) $74 - 70 =$

32 Resuelve.

Mirna tiene 35 aguacates. Si 30 están maduros, ¿cuántos aguacates están verdes?

PO: _____

R: _____

33 Resta.

a) $36 - 6 =$

b) $28 - 8 =$

c) $93 - 3 =$

d) $77 - 6 =$

Lección 8

Sigamos restando

34 Resta en forma vertical.

a) $27 - 14$

b) $72 - 41$

c) $54 - 31$

d) $68 - 25$

-		

35 Resta en forma vertical.

a) $29 - 24$

b) $36 - 32$

c) $69 - 62$

d) $57 - 53$

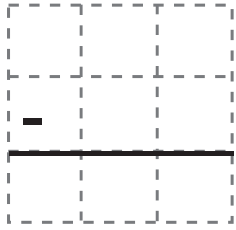

e) $78 - 76$

f) $87 - 83$

g) $48 - 45$

h) $95 - 91$

36 Resta en forma vertical.

a) $46 - 5$

b) $28 - 5$

c) $49 - 6$

d) $37 - 4$

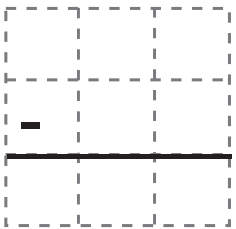

e) $28 - 3$

f) $64 - 2$

g) $89 - 3$

h) $96 - 5$

37

Resuelve.

Hay 27 sandías y 4 piñas.

¿Cuántas sandías más que piñas hay?

PO: _____

R: _____

Cálculo

Lección 9

Restemos prestando

38

Resta en forma vertical.

a) $95 - 38$

b) $76 - 59$

c) $43 - 25$

d) $32 - 16$

e) $52 - 27$

f) $71 - 54$

g) $84 - 48$

h) $65 - 17$

39

Resuelve.

José cosechó 63 guineos y vendió 46.

¿Cuántos guineos le quedan?

PO: _____

R: _____

Cálculo

40 Resta en forma vertical.

$$\begin{array}{r} 50 \\ - 25 \\ \hline \end{array}$$

b) $60 - 18$

c) $90 - 46$

d) $30 - 16$

e) $80 - 59$

f) $70 - 37$

41 Resuelve.

Hay 70 flores entre rojas y blancas. Si 36 son rojas, ¿cuántas flores blancas hay en el jardín?

Cálculo

PO: _____ R: _____

42 Resta en forma vertical.

$$\begin{array}{r} 72 \\ - 68 \\ \hline \end{array}$$

b) $45 - 37$

c) $92 - 84$

d) $53 - 46$

e) $31 - 23$

f) $42 - 35$

g) $71 - 67$

h) $84 - 79$

43 Resuelve.

a) Rosita tiene 24 libros y su hermano tiene 19.

¿Cuántos libros más que su hermano tiene Rosita?

PO: _____ R: _____

Cálculo

--

b) Inventa problema del PO: $25 - 16$

PO:
R:

Cálculo

--

44 Resta en forma vertical.

a)
$$\begin{array}{r} 42 \\ - 9 \\ \hline \end{array}$$

b) $53 - 9$

c) $75 - 8$

d) $65 - 6$

e) $28 - 9$

f) $70 - 2$

g) $80 - 4$

h) $60 - 7$

Nos divertimos

Encuentra la ruta que siguió Angelita.

- Realiza todas las operaciones.
- Pinta de amarillo las casillas que tienen respuesta 48.

Entrada



$\begin{array}{r} 23 \\ - 7 \\ \hline \end{array}$	$\begin{array}{r} 56 \\ - 8 \\ \hline \end{array}$	$\begin{array}{r} 78 \\ - 30 \\ \hline \end{array}$	$\begin{array}{r} 84 \\ - 34 \\ \hline \end{array}$
$\begin{array}{r} 56 \\ - 28 \\ \hline \end{array}$	$\begin{array}{r} 65 \\ - 17 \\ \hline \end{array}$	$\begin{array}{r} 75 \\ - 29 \\ \hline \end{array}$	$\begin{array}{r} 54 \\ - 16 \\ \hline \end{array}$
$\begin{array}{r} 45 \\ - 15 \\ \hline \end{array}$	$\begin{array}{r} 73 \\ - 25 \\ \hline \end{array}$	$\begin{array}{r} 89 \\ - 41 \\ \hline \end{array}$	$\begin{array}{r} 70 \\ - 22 \\ \hline \end{array}$
$\begin{array}{r} 33 \\ - 8 \\ \hline \end{array}$	$\begin{array}{r} 93 \\ - 21 \\ \hline \end{array}$	$\begin{array}{r} 55 \\ - 30 \\ \hline \end{array}$	$\begin{array}{r} 81 \\ - 33 \\ \hline \end{array}$



Unidad 10



Comparemos y compremos

Lección 1

Comparemos longitudes

1) Compara las longitudes y contesta las preguntas.

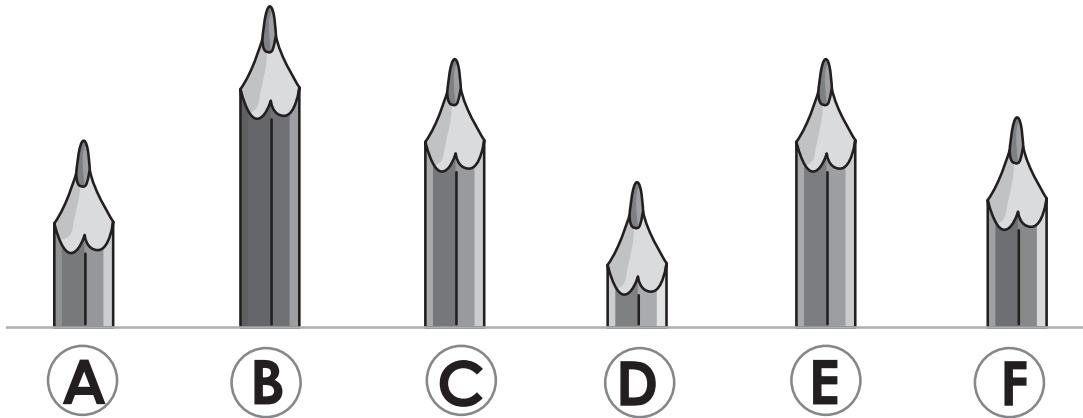

a) ¿Cuál es más largo que **C**? _____

b) ¿Cuál es menos largo que **A**? _____

c) ¿Cuál es igual de largo que **E**? _____

2) Compara las longitudes y colorea la letra del más largo.

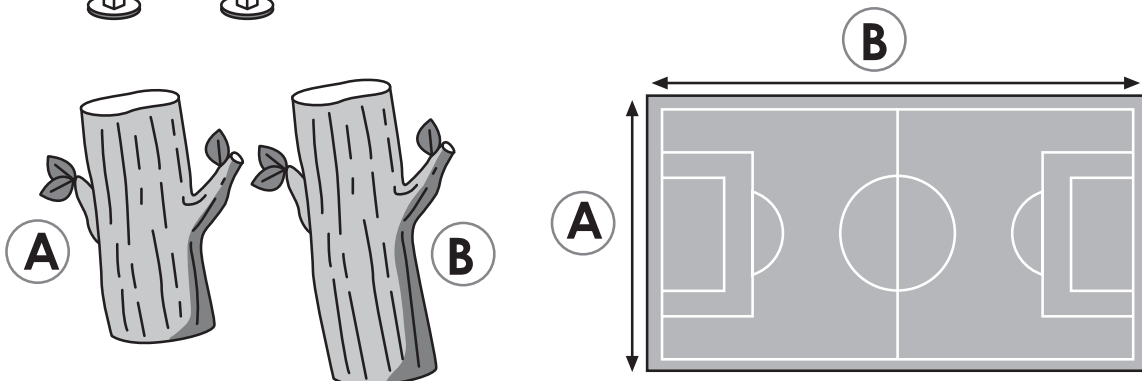
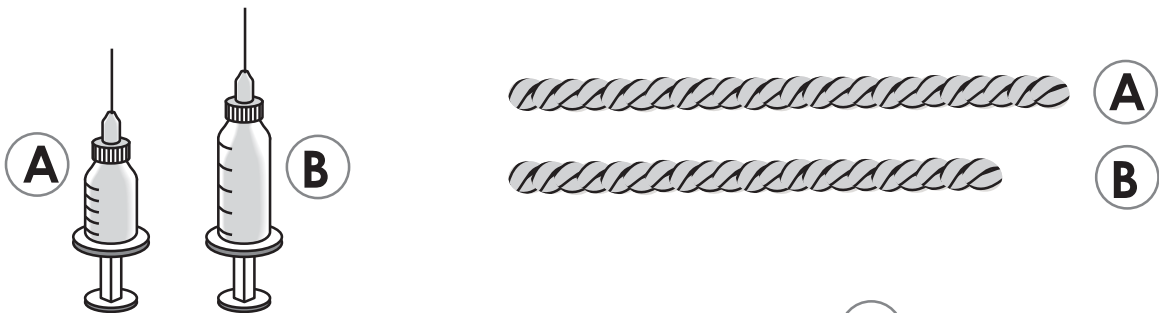

3 Observa y une con una línea la unidad de medida con su nombre.

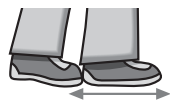

● paso



● pulgada



● brazada



● mano

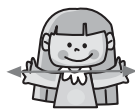

● pie



● cuarta



● jeme

4 Toma los objetos y mídelos.

objeto	Medidas			
	pulgadas	jemes	cuartas	pies
Libro de texto				
Cuaderno de ejercicios				
Cuaderno de apuntes				
Bolsón				

Lección 2

Comparemos pesos

- 5 Encierra el objeto menos pesado.

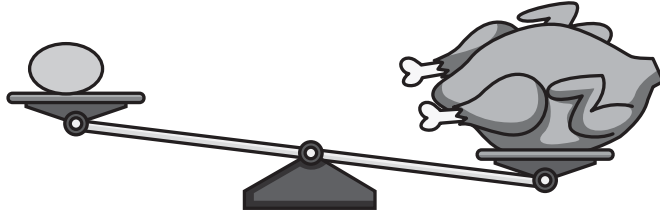

Lección 4

Contemos monedas

- 6 Une con una línea las cantidades con las monedas correspondientes.



25 centavos •



10 centavos •



20 centavos •





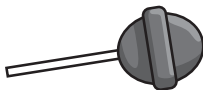









5 centavos •















6 centavos •



7 Une con una línea la cantidad y las monedas que la forman.

			•	• 35 centavos
			•	• 45 centavos
			•	• 75 centavos
			•	• 40 centavos

8 Encuentra cuántos centavos tiene cada persona.

	Ana tiene			_____ centavos	
	José tiene				_____ centavos
	Luis tiene				_____ centavos
	María tiene				_____ centavos

Lección 5

Conozcamos el billete de dólar

9) Contesta. ¿Cuáles grupos de monedas equivalen a un dólar?



R:

10) ¿Cuánto te sobra, si pagas con las monedas indicadas en cada ejercicio?

a) R: _____

b) R: _____

c) R: _____

d) R: _____



Páginas Para recortar

Azulejos Unidades 1, 2, 4, 5, 7 y 9

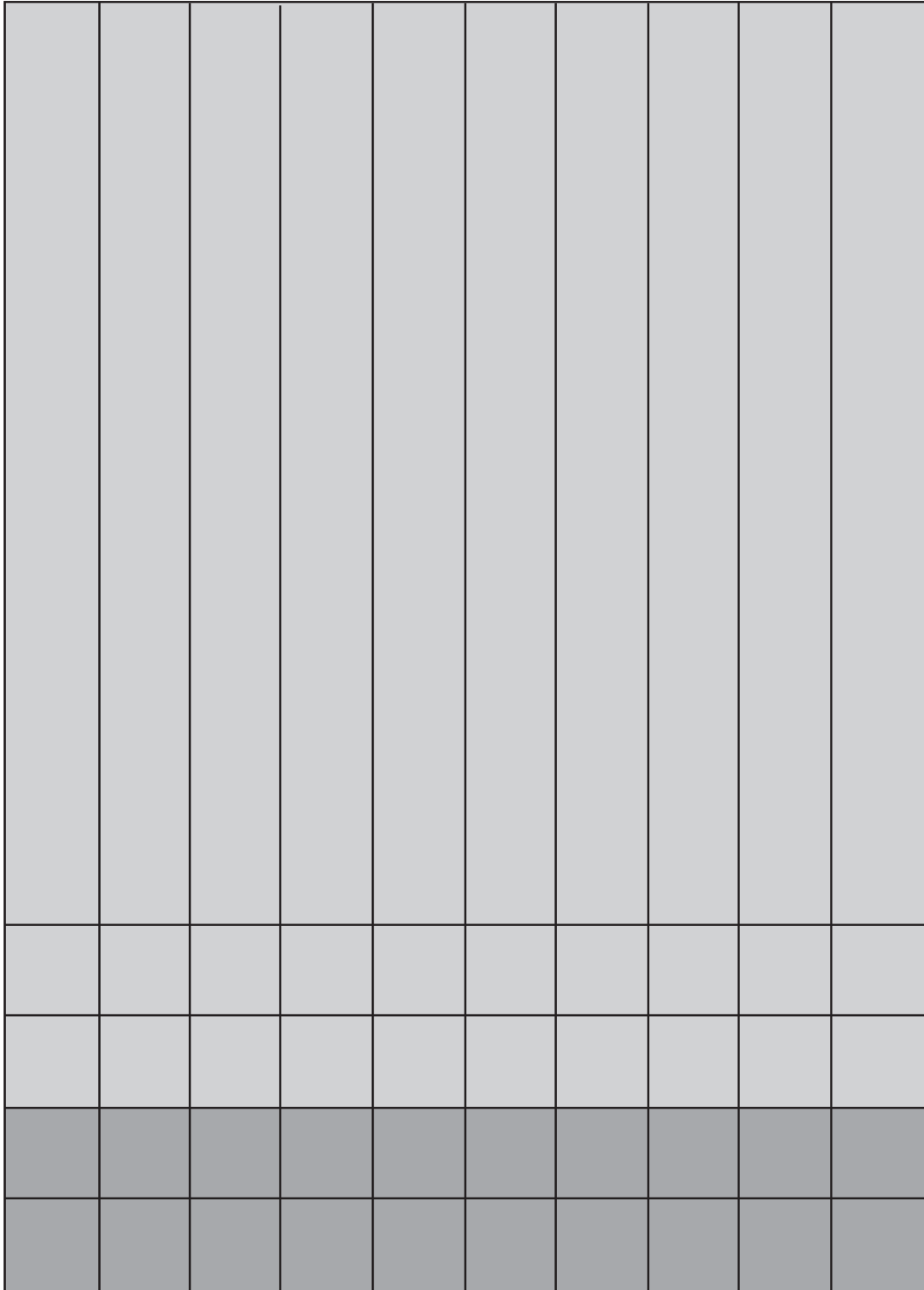

Tarjetas con marcas Unidad 2, 4, 5 y 7

